

TAG: _____

SUBMITTAL

5 Ton Convertible Heat Pump Packaged Units 4WCY4060A3000C

PRODUCT SPECIFICATIONS

MODEL	4WCY4060A3000C
RATED Volts/Ph/Hz	208-230/3/60
Performance Cooling BTUH^①	58000
Indoor Airflow (CFM)	1780
Power Input (KW)	4.95
EER/SEER (BTU/Watt-Hr.) ^⑥	11.5 / 14.0
Sound Power Rating [dB(A)] ^②	76
Performance Heating^①	
(High Temp.)BTUH	55000
Power Input (KW)	4.60
(Low Temp.) BTUH	37600
Power Input (KW)	4.29
HSPF (BTU / Watt-Hr.) ^⑥	8.0
POWER CONN. — V/Ph/Hz	208-230/3/60
Min. Brch. Cir. Ampacity ^③	28.6
Fuse Size — Max. (amps)	45
Fuse Size — Recmd. (amps)	45
COMPRESSOR	SCROLL
Volts/Ph/Hz	208-230/3/60
R.L. Amps — L.R. Amps	16.0 / 110
OUTDOOR COIL — TYPE	SPINE-FIN
Rows/F.P.I.	2 / 24
Face Area (sq.ft.)	23.57
Tube Size (in.)	3/8
Refrigerant Control	EXPANSION VALVE
INDOOR COIL — TYPE	PLATE FIN
Rows/F.P.I.	4 / 15
Face Area (sq.ft.)	5.0
Tube Size (in.)	3/8
Refrigerant Control	EXPANSION VALVE
Drain Conn. Size (in.)	3/4 FEMALE NPT
OUTDOOR FAN — TYPE	PROPELLER
Dia. (in.)	28.2
Drive/No. Speeds	DIRECT / 1
CFM @ 0.0 in. w.g. ^④	5700
Motor — HP/R.P.M.	1/3 / 830
Volts/Ph/Hz	230/1/60
F.L. Amps/L.R. Amps	1.7 / 3.5
INDOOR FAN — TYPE	CENTRIFUGAL
Dia x Width (in.)	11 X 10
Drive/No. Speeds	DIRECT / VARIABLE
CFM @ 0.0 in. w.g. ^⑤	SEE FAN PERFORMANCE TABLE
Motor — HP/R.P.M.	1 / VARIABLE
Volts/Ph/Hz	208-230/1/60
F.L. Amps/L.R. Amps	6.9 / 6.9
FILTER / FURNISHED	NO
Type Recommended	THROWAWAY
Recmd. Face Area (sq. ft.) ^⑦	5.3
REFRIGERANT	R410A
Charge (lbs.)	10.125
DIMENSIONS	H X W X L
Crated (in.)	51.86 / 47.4 / 61.75
WEIGHT	
Shipping (lbs.) / Net (lbs.)	623 / 495

① Certified in accordance with the Unitary Air-Conditioner Equipment certification program, which is based on AHRI Standard 210/240.

② Sound Power values are not adjusted for AHRI 270-95 tonal corrections.

③ Calculated in accordance with currently prevailing Nat'l Electrical Code.

④ Standard Air — Dry Coil — Outdoor.

⑤ Standard Air — Wet Coil — Indoor.

⑥ Rated in accordance with D.O.E. test procedure.

⑦ Filters must be installed in return air system. Square footages listed are based on 300 f.p.m. face velocity. If permanent filters are used size per manufacturer's recommendations with clean resistance of 0.05" W.C.

Dimensional Data and Weights

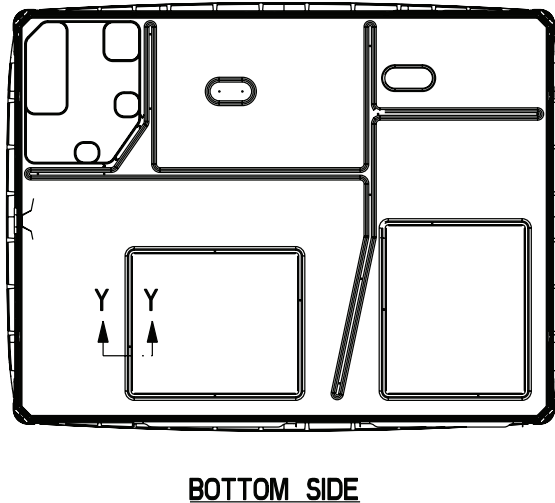
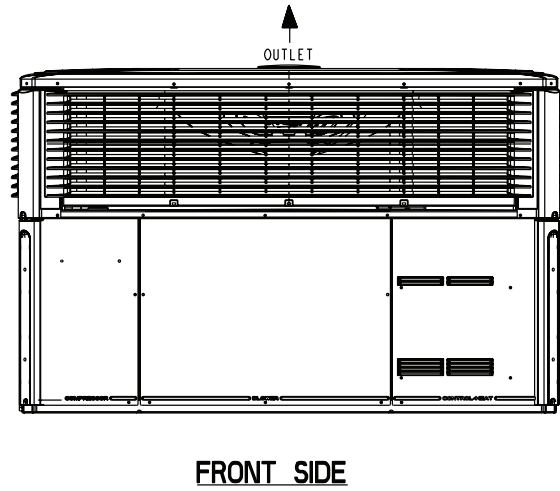
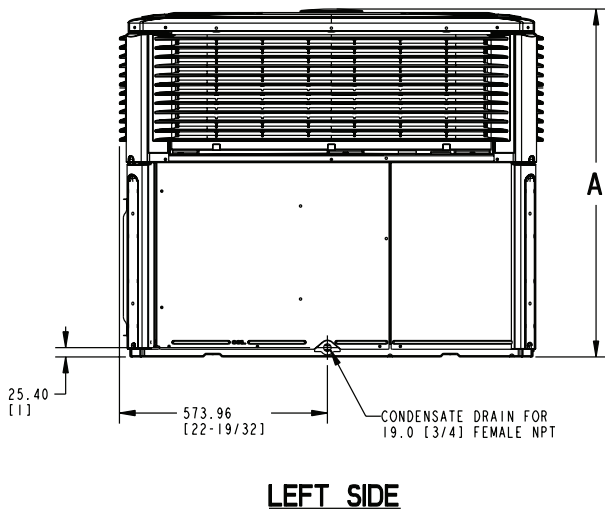
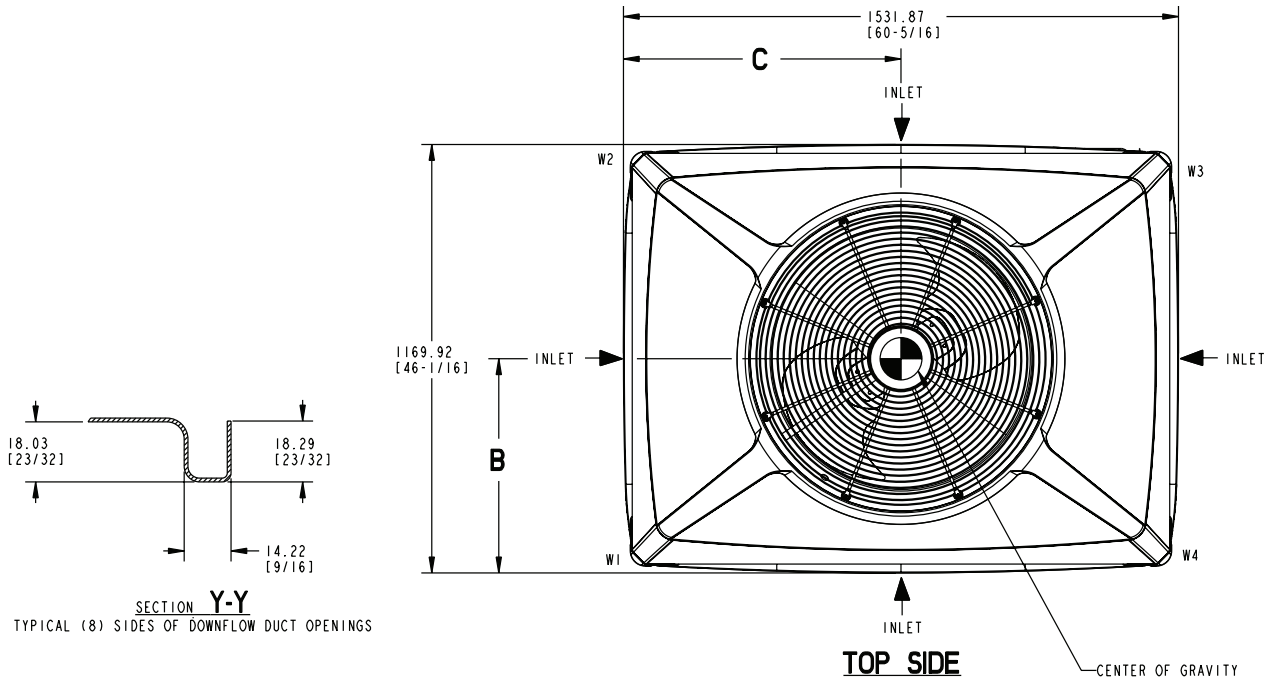

NOTE: The view labeled "Bottom Side" represents the Base as viewed looking up from underneath the unit.

4WCY4042A through 4WCY4060A (1 of 3)

Dimensional Data and Weights

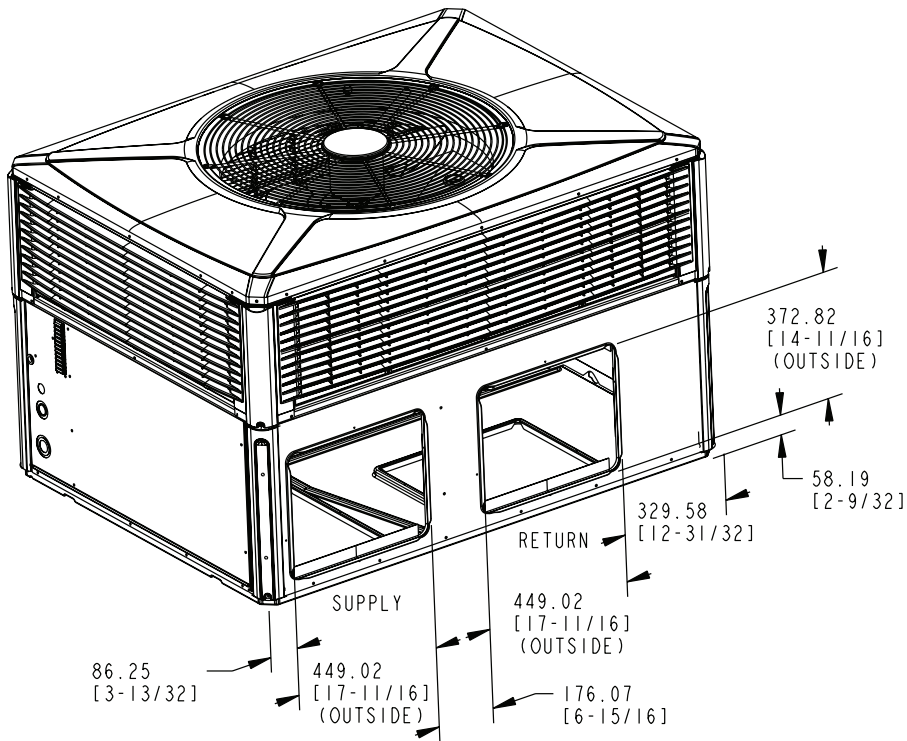

BACK DUCT OPENINGS

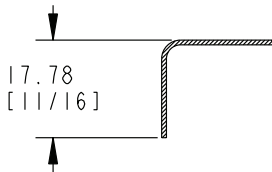

SECTION X-X

TYPICAL (8) SIDES OF SIDEFLOW DUCT OPENINGS

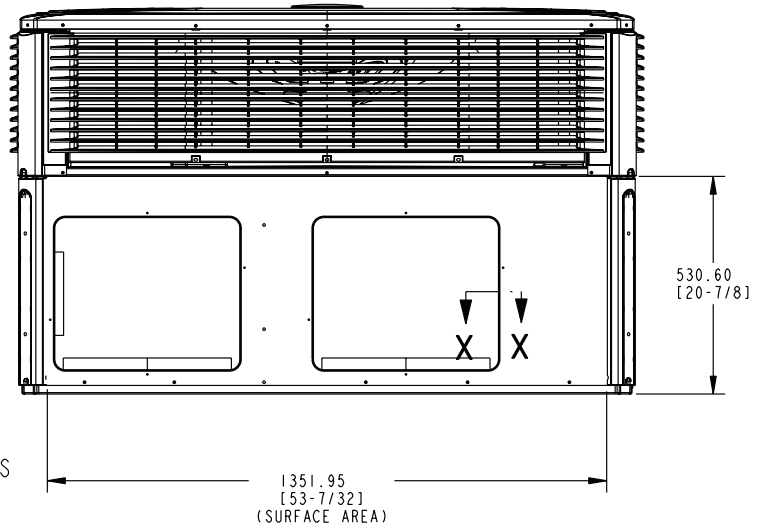

BACK SIDE

MODEL	HEIGHT MM/IN.	APPROX. CORNER WEIGHT - KG/LBS				SHIPPING WEIGHT KG/LBS	TOTAL UNIT WEIGHT KG/LBS	CENTER OF GRAVITY MM/IN.	
	A	W1	W2	W3	W4			B	C
4TCY4042/048A	949.33 [37-3/8]	76.2 [168]	47.6 [105]	35.8 [79]	57.6 [127]	275.6 (607)	217.3 [479]	426.7 [16.8]	635.0 [25.0]
4TCY4048B	949.33 [37-3/8]	78.0 [172]	49.4 [109]	37.6 [83]	59.4 [131]	282.5 [623]	224.4 [495]	426.7 [16.8]	635.0 [25.0]
4TCY4060	1050.93 [41-3/8]	78.9 [174]	46.7 [103]	34.9 [77]	59.1 [130]	277.8 (612)	219.5 [484]	414.0 [16.3]	635.0 [25.0]
4WCY4042/048A	949.33 [37-3/8]	68.9 [152]	40.8 [90]	30.8 [68]	52.2 [115]	275.6 (607)	217.5 [479]	414.0 [16.3]	635.0 [25.0]
4WCY4048B	949.33 [37-3/8]	78.0 [172]	49.4 [109]	37.6 [83]	59.4 [131]	282.5 [623]	224.4 [495]	414.0 [16.3]	635.0 [25.0]
4WCY4060	1050.93 [41-3/8]	80.3 [177]	47.6 [105]	35.8 [79]	60.8 [134]	282.8 (623)	224.5 [495]	414.0 [16.3]	635.0 [25.0]
4WCZ6048	1050.93 [41-3/8]	68.9 [152]	40.8 [90]	30.8 [68]	52.2 [115]	275.6 (607)	217.5 [479]	414.0 [16.3]	635.0 [25.0]
4WCZ6060	1050.93 [41-3/8]	80.3 [177]	47.6 [105]	35.8 [79]	60.8 [134]	282.8 (623)	224.5 [495]	414.0 [16.3]	635.0 [25.0]

4WCY4042A through 4WCY4060A (3 of 3)

Unit Performance Data

Indoor Fan Performance 4WCY4060

Horizontal Airflow

4WCY4060-HOR	DIPSWITCH SETTINGS				External Static Pressure (in. wg)											
AIRFLOW SETTING	1	2	3	4		0.0	0.1	0.2	0.3	0.4	0.5	0.6	0.7	0.8	0.9	1.0
350 CFM/TON	OFF	OFF	OFF	ON	Watts	394	427	464	504	548	591	633	668	-	-	-
					CFM	1673	1772	1799	1793	1779	1771	1767	1756	-	-	-
400 CFM/TON*	OFF	OFF	OFF	OFF	Watts	695	642	660	710	764	811	849	893	966	-	-
					CFM	2054	2036	2031	2032	2033	2031	2023	2012	2002	-	-

Down Airflow

4WCY4060-DOWN	DIPSWITCH SETTINGS				External Static Pressure (in. wg)											
AIRFLOW SETTING	1	2	3	4		0.0	0.1	0.2	0.3	0.4	0.5	0.6	0.7	0.8	0.9	1.0
350 CFM/TON	OFF	OFF	OFF	ON	Watts	443	461	493	532	571	607	642	680	-	-	-
					CFM	1796	1741	1726	1725	1722	1712	1698	1692	-	-	-
400 CFM/TON*	OFF	OFF	OFF	OFF	Watts	740	697	715	763	819	866	892	894	872	-	-
					CFM	2012	1987	1979	1977	1976	1969	1950	1913	1852	-	-

*Factory Default Setting

4WCY4060 AIRFLOW WITH AUXILIARY HEAT (CFM)

SWITCH SETTINGS		SELECTION	NOMINAL AIRFLOW
7-OFF	8-OFF	LOW	1400 CFM
7-ON	8-OFF	HIGH	1600 CFM
7-OFF	8-ON	HIGH	1600 CFM
7-ON	8-ON	HIGH	1600 CFM

BAYHTRV305, 308, 310, 315, 320, 325E Supplementary Electric Heater

UNIT MODEL	ELECTRIC HEATER MODEL	RATED VOLTAGE	PHASE	AMPS	HEATER CAPACITY		NO. OF STAGES	KW/STAGE		MCA	MAX FUSE OR HACR CKT BKR SIZE (4)	CANADA ONLY MAX. CKT BKR SIZE (5)
					KW	BTUH		1	2			
^W/TCY4036-060A3	BAYHTRV305E	208/240	3	10/12	3.76/5.0	12800/17100	1	3.76/5.0		13/15	15/15	15/15
^W/TCY4036-060A3	BAYHTRV308E	208/240	3	17/19	6.0/8.0	20500/27300	1	6.0/8.0		21/24	25/25	25/25
^W/TCY4036-060A3	BAYHTRV310E	208/240	3	21/24	7.5/10.0	25600/34100	1	7.5/10.0		26/30	30/30	30/30
^W/TCY4036-060A3	BAYHTRV315E	208/240	3	31/36	11.27/15.0	38500/51200	2	7.5/10.0	3.76/5.0	39/45	40/45	40/45
^W/TCY4048-060A3	BAYHTRV320E	208/240	3	42/48	15.0/20.0	51200/68300	2	7.5/10.0	7.5/10.0	52/60	60/60	60/60
^W/TCY4048-060A3	BAYHTRV325E#	208/240	3	52/60	18.78/25.0	64100/85300	2	11.26/15.0	7.5/10.0	65/75	70/80	70/80

BAYSPEK62, 63E Single Power Entry Kit

SINGLE POWER ENTRY KIT	HEATER MODEL	UNIT MODEL
BAYSPEK061E	BAYHTRV305E	4WCY4036-060A3
	BAYHTRV308E	4WCY4036-060A3
	BAYHTRV310E	4WCY4036-048A3
BAYSPEK064E	BAYHTRV315E	4WCY4036-060A3
	BAYHTRV320E	4WCY4048A-060A3
BAYSPEK065E	BAYHTRV310E	4WCY4060A3

BAYCURB051A Full Perimeter Roof Mounting Curb for ***042-060**

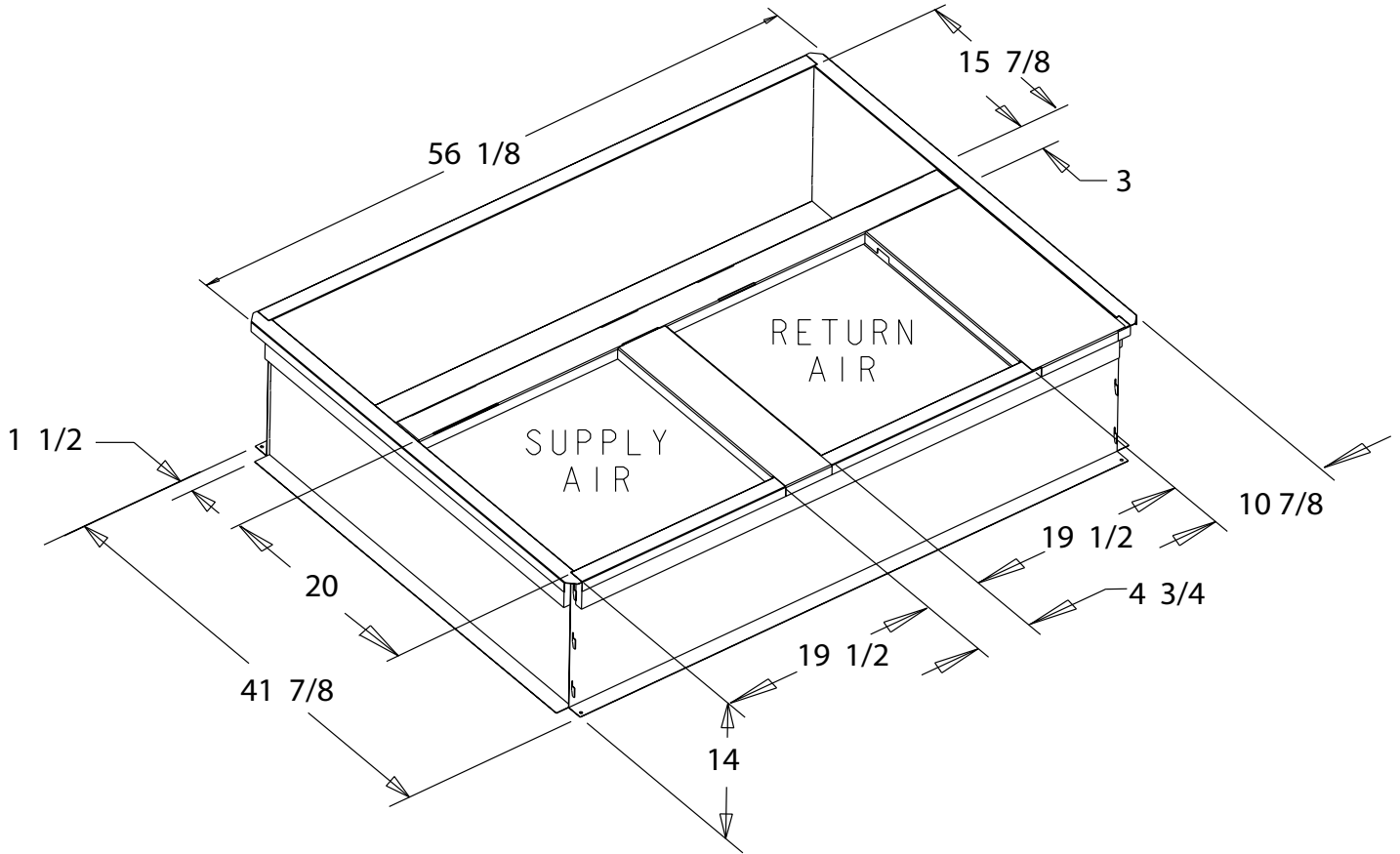

The drawings on this page are prepared by the manufacturer in order to provide detail regarding job layout only. These drawings are not intended to be used as a basis to construct, build or modify the items depicted in the drawings. The manufacturer is not responsible for the unauthorized use of these drawings and expressly disclaims any liability for damages resulting from such unauthorized use.

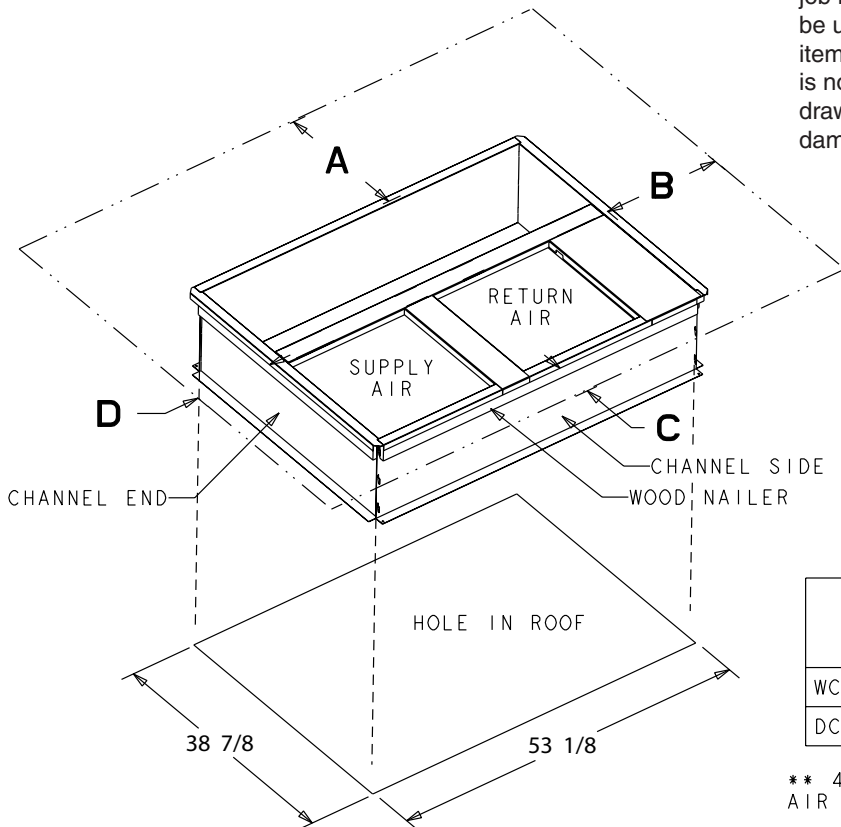

	SERVICE CLEARANCE DIMENSIONS			
	A	B	C	D
WC*/TC*	42.00	36.00	12.00**	24.00
DC*/YC*	42.00	36.00	12.00**	36.00

** 42.00 WITH ECONOMIZER WITH 25% FRESH AIR ACCESSORY

Optional Equipment

BAYFLTR101, 201B, 1" - 2" Filter Rack (Mounts in Filter/Coil Section)

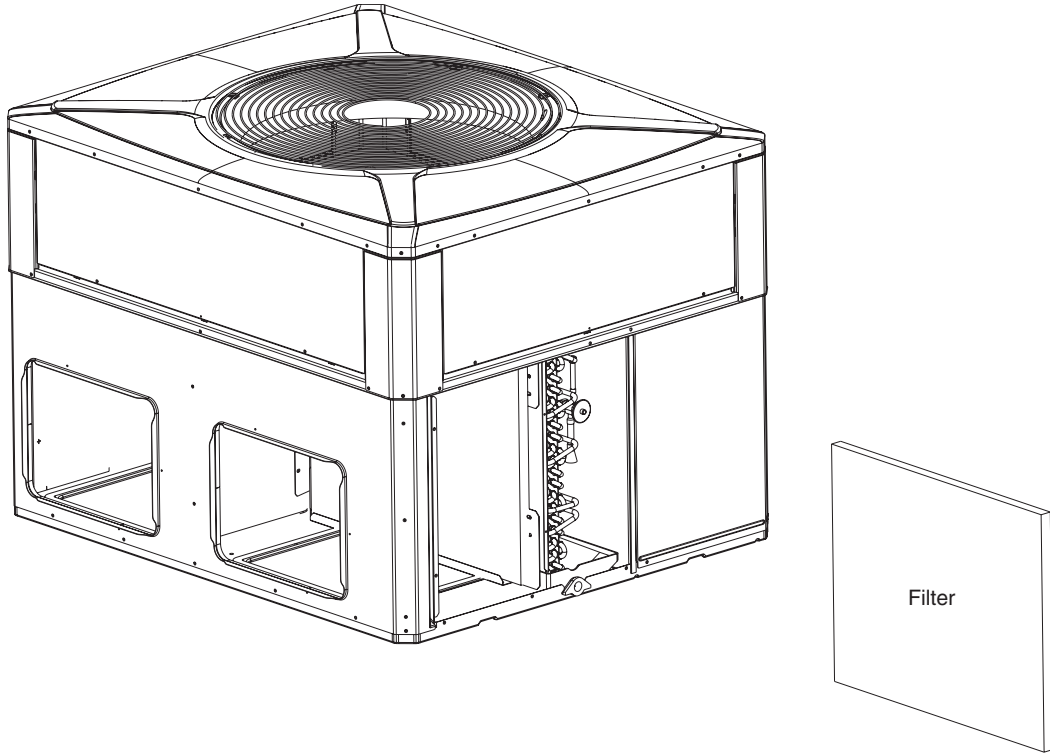

BAYACCDOR1A & BAYACCDOR2A Hinged Filter Access Door Replaces Filter/Coil Access Panel

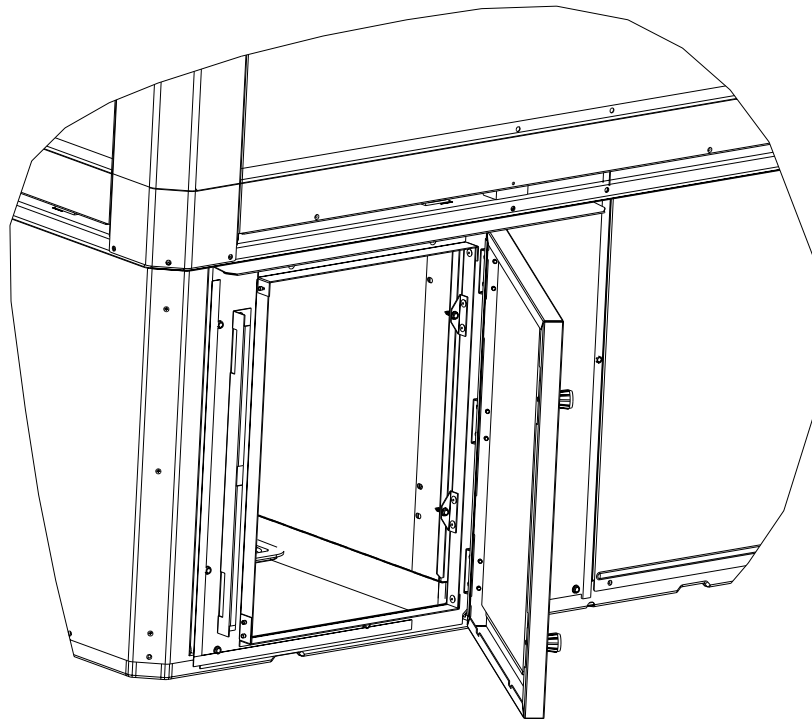

The drawings on this page are prepared by the manufacturer in order to provide detail regarding job layout only. These drawings are not intended to be used as a basis to construct, build or modify the items depicted in the drawings. The manufacturer is not responsible for the unauthorized use of these drawings and expressly disclaims any liability for damages resulting from such unauthorized use.

Optional Equipment

BAYECON101,102A Down Discharge Economizer and Rain Hood (Mounts Over Horizontal Return Air Opening)

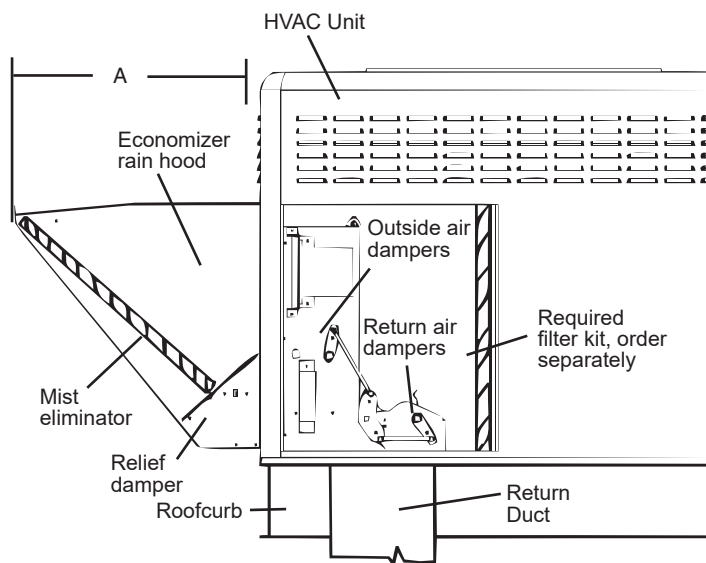

Economizer	Unit Application Models	A
BAYECON101A	4TC*, WC*, YC*, DC* *018-036	20.125"
BAYECON102A	4TC*, WC*, YC*, DC* *042-060	24.375"

BAYCON200,201A Horizontal Economizer and Rain Hood

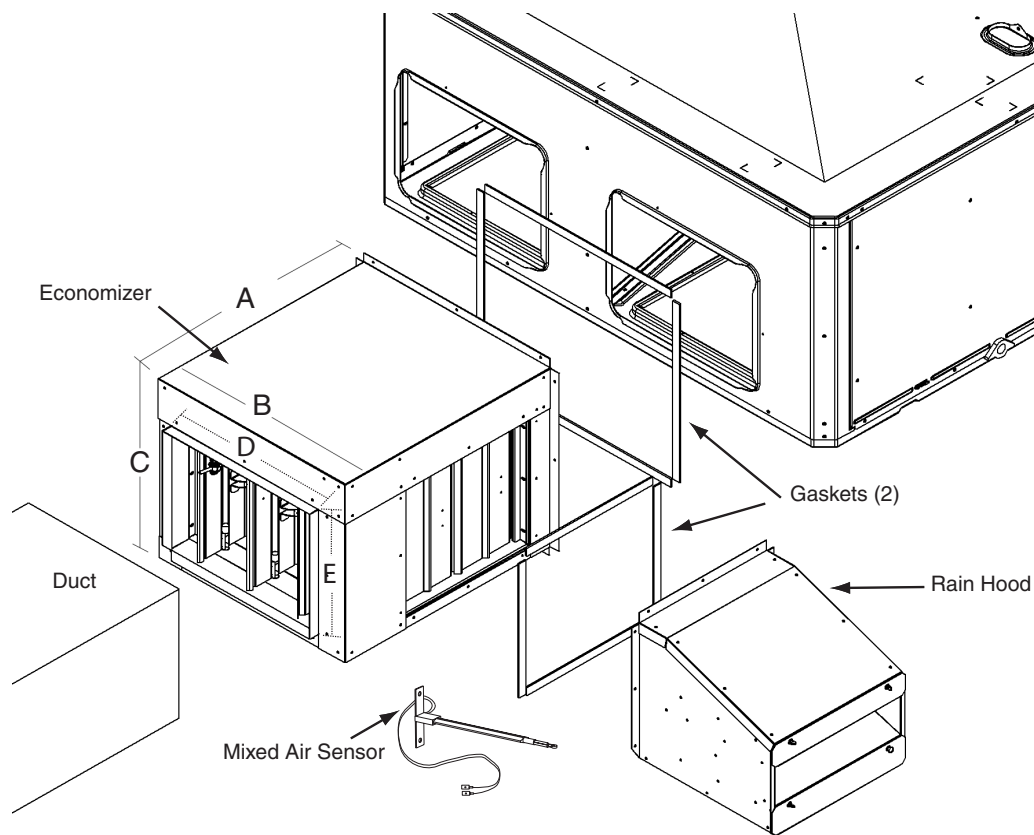

The drawings on this page are prepared by the manufacturer in order to provide detail regarding job layout only. These drawings are not intended to be used as a basis to construct, build or modify the items depicted in the drawings. The manufacturer is not responsible for the unauthorized use of these drawings and expressly disclaims any liability for damages resulting from such unauthorized use.

Economizer	A	B	C	D	E	F
BAYECON200AA	22"	20"	16 7/8"	15 11/16	11 11/16	15
BAYECON201AA	26"	22 21/32"	19"	17 11/16	14 11/16	21-3/8

Optional Equipment

BAYOSAH001,002A, 25% Outside Air Damper (Replaces Filter/Coil Access Panel)

The drawings on this page are prepared by the manufacturer in order to provide detail regarding job layout only. These drawings are not intended to be used as a basis to construct, build or modify the items depicted in the drawings. The manufacturer is not responsible for the unauthorized use of these drawings and expressly disclaims any liability for damages resulting from such unauthorized use.

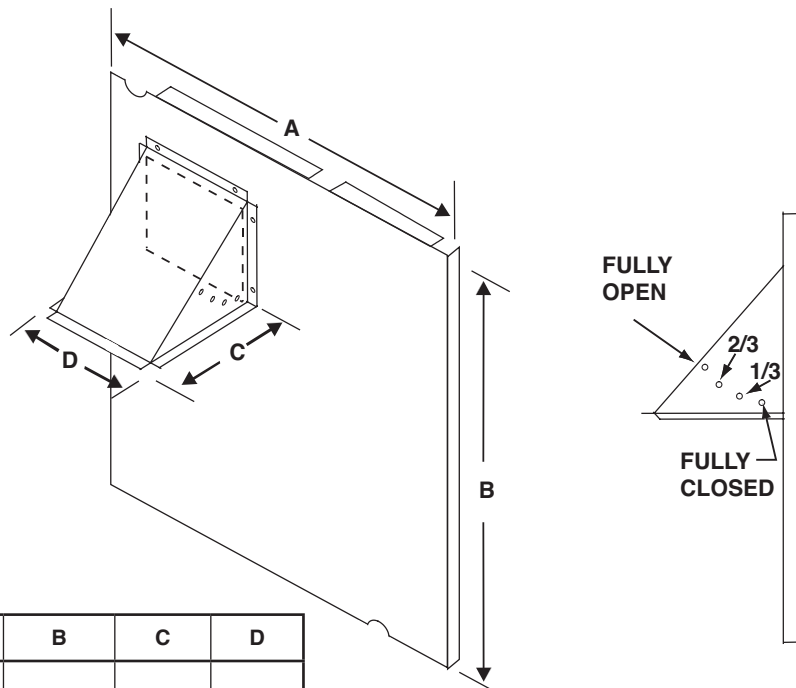

Manual Fresh Air Model	Unit Application Models	A	B	C	D
BAYOSAH001	4YC,WC3018-036 4TC*3018-036 4W/T/Y/DCY4024-036 4W/Y/DCZ6036	22 7/16"	20 11/16"	12 3/8"	9 3/16"
BAYOSAH002	4YC,WC3042-060 4TC*3042-060 4W/T/Y/DCY4042-060 4W/Y/DCZ6048-060	25 3/16"	20 11/16"	12 3/8"	9 3/16"

BAYDMPR101,102A, 25% Motorized Outside Air Damper (Mounts Over Horizontal Return Air Opening)

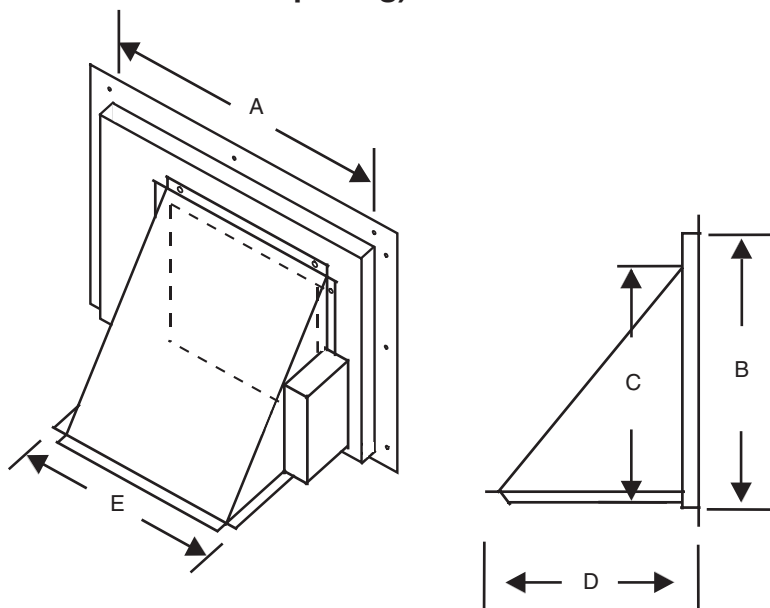

	Unit Application Models	A	B	C	D	E
BAYDMPR101A	4YC,WC3018-036 4TC3018-036 4W/T/Y/DCY4024-036 4W/Y/DCZ6036	15 13/16"	11 13/16"	10 1/4"	11 1/2"	12 1/4"
BAYDMPR102A	4YC,WC3042-060 4TC3042-060 4W/T/Y/DCY4042-060 4W/Y/DCZ6048-060	18 3/16"	15 1/8"	10 1/4"	11 1/2"	12 1/4"

Mechanical Specifications

General

The units shall be horizontal airflow as shipped and convertible to downflow. All units shall be factory assembled, piped, internally wired and fully charged with refrigerant. All units shall be factory run tested to check cooling operation, fan and blower rotation and control or TXV sequence. Units shall be designed to operate at ambient temperatures between 115°F and 55°F in cooling as manufactured. Cooling performance shall be rated in accordance with A.H.R.I. standards.

Unit Casing

All components shall be mounted in a weather-resistant steel cabinet with an enamel finish. Access panels shall be provided for unit controls and indoor coil and fans. Indoor air section compartment shall be completely insulated with fireproof, permanent, odorless glass fiber material. Knockouts shall be provided for utility and control connections. Drain connections shall be provided to accommodate indoor water runoff.

Compressor

The compressor shall be hermetically sealed, high efficiency Climatuff® compressors. Internal overcurrent and over temperature protection, internal pressure relief shall be standard.

Refrigeration System

All units shall have TXV in cooling and TXV in heating. Service pressure tap ports, and a refrigerant line filter dryer shall be standard.

Indoor Coil

Coils shall be internally finned or smooth bore 3/8" copper tubes mechanically bonded to configured aluminum plate fin as standard. Evaporator coil leak and pressure tested to 200 psig; condenser coil tested to 450 psig.

Condenser Coil —

The Spine Fin™ condenser coil shall be continuously wrapped, corrosion resistant all aluminum with minimum brazed joints. This coil is 3/8 inch O.D. seamless aluminum tubing glued to a continuous aluminum fin. Coils are lab tested to withstand 2,000 pounds of pressure per square inch. The outdoor coil provides low airflow resistance and efficient heat transfer. The coil is protected on all four sides by louvered panels.

Indoor Air Fan — Direct-drive, forward-curved, centrifugal wheel in a Composite Vortica® Blower housing. Motor shall have thermal overload protection. Permanently lubricated motor bearings. Motor/blower assembly isolated from unit with rubber mounts.

Condenser Fan — Direct-drive, draw thru propeller type. Weather-proofed permanent split capacitor fan motor shall have built-in thermal overload and permanently lubricated motor bearings.

System Controls

System controls include condenser fan, evaporator fan and compressor contactors.

Accessories

Roof Curb — The roof curb shall be designed to mate with the unit and provide support and complete weathertight installation when properly installed. Adhesive back polyurethane sealing strips shall be provided to ensure an airtight seal between supply and return openings of the curb and unit. The roof curb design allows field fabricated ductwork to be connected directly to the curb. Curb ships knocked down for field assembly, and includes factory-installed wood nailer strips.

Electric Heaters — Each heater assembly shall include power supply fusing if over 48 amps, automatic resetting limit switches and heat limiters for thermal protection. Heaters shall be provided with polarized plugs for quick connection to unit low voltage wiring. Electric heat modules shall be UL listed.

Single Source Power Entry — This accessory when used with electric heat accessory shall allow single source power connection to unit and heater combination. Single source power entry kits shall have specific matching heater(s). Kit shall include high voltage terminal blocks, fuse blocks and fuses, cut-to-length interconnecting wiring, and junction box (if required) to provide power sources with fuse protection as required for both the unit and accessory heater. Kit components shall install within the unit cabinet in the heater access section. Single source branch power circuit shall be protected and wired in accordance with local codes.

Fully Modulating Economizer — This accessory shall be field installed and be composed of the following items: 0-100% fresh air damper, damper drive motor, fixed dry bulb enthalpy control, and low voltage wiring plug for electrical connections. Solid state enthalpy or differential enthalpy control is optional. Economizer operations shall be controlled by the preset position of the enthalpy control. A barometric relief damper shall be standard with the economizer and provide a pressure operated damper that shall be gravity closing and prohibit entrance of outside air on equipment "off" cycle. Economizer requires BAYRLAY004A relay kit to interface the economizer to the heat pump.

Manual Outside Air Dampers — Rain hood and screen shall be field installed. Suitable for up to 25% outside air.

Start Kit — Extra compressor starting capacity for single phase equipment.

Control Options

Standard Indoor Thermostats — Two stage heating/cooling or one stage heating/cooling thermostats shall be available in either manual or automatic changeover.

Programmable Electronic Night Setback Thermostat — Programmable electronic thermostat shall provide heating setback and cooling setup with 7-day, programming capability. 1H/1C or 2H/2C models available.

About Trane and American Standard Heating and Air Conditioning

Trane and American Standard create comfortable, energy efficient indoor environments for residential applications. For more information, please visit www.trane.com or www.americanstandardair.com

The manufacturer has a policy of continuous data improvement and it reserves the right to change design and specifications without notice. We are committed to using environmentally conscious print practices.

4WCY4060A-SUB-3E-EN 03 Jun 2020

Supersedes 4WCY4060A-SUB-3D (November 2012)



The AHRI Certified mark indicates company participation in the AHRI Certification program. For verification of individual certified products, go to ahridirectory.org.

© 2020