

# Submittal

## Single Packaged Heat Pump 15 SEER Convertible

4WCY5024A1000A

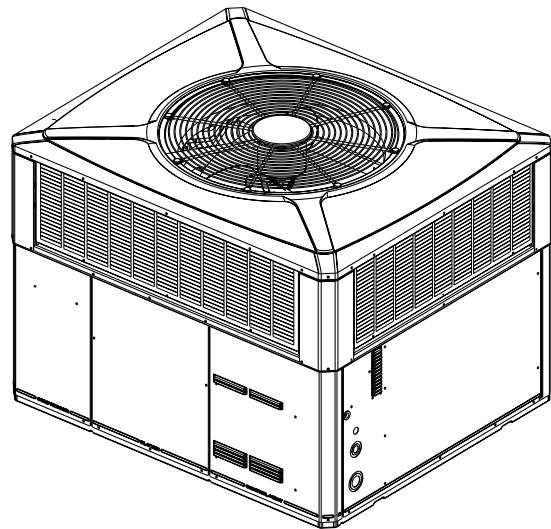

*Note: Graphics in this document are for representation only. Actual model may differ in appearance.*

# SAFETY SECTION

**Important** — This document contains a wiring diagram, a parts list, and service information. This is customer property and is to remain with this unit. Please return to service information pack upon completion of work.

## ⚠ WARNING

### HAZARDOUS VOLTAGE!

Failure to follow this Warning could result in property damage, severe personal injury, or death.

Disconnect all electric power, including remote disconnects before servicing. Follow proper lockout/tagout procedures to ensure the power cannot be inadvertently energized.

## ⚠ WARNING

### SAFETY AND ELECTRICAL HAZARD!

Failure to follow this Warning could result in property damage, severe personal injury, or death.

These servicing instructions are for use by qualified personnel only. To reduce the risk of electrical shock, do not perform any servicing other than that contained in these operating instructions unless you are qualified to do so.

## ⚠ CAUTION

### GROUNDING REQUIRED!

Failure to inspect or use proper service tools may result in equipment damage or personal injury. Reconnect all grounding devices. All parts of this product that are capable of conducting electrical current are grounded. If grounding wires, screws, straps, clips, nuts, or washers used to complete a path to ground are removed for service, they must be returned to their original position and properly fastened.

## ⚠ WARNING

### UNIT CONTAINS R-410A REFRIGERANT!

Failure to use proper service tools may result in equipment damage or personal injury.

R-410A operating pressure exceeds the limit of R-22. Proper service equipment is required. Service using only R-410A Refrigerant and approved POE compressor oil.

## ⚠ WARNING

### SAFETY HAZARD!

Operating the unit without the access panels properly installed may result in severe personal injury or death.

Do not operate the unit without the evaporator fan access panel or evaporator coil access panel in place.

## ⚠ WARNING

### WARNING!

This product can expose you to chemicals including lead, which are known to the State of California to cause cancer and birth defects or other reproductive harm. For more information go to [www.P65Warnings.ca.gov](http://www.P65Warnings.ca.gov).

**Important:** Wear appropriate gloves, arm sleeve protectors and eye protection when servicing or maintaining this equipment.

**Important:** Air filters and media wheels or plates shall meet the test requirements in UL 900.

# Product Specifications

<b>MODEL</b>	4WCY5024A1000A
RATED Volts/PH/Hz	208-230/1/60
Performance Cooling BTUH <sup>(a)</sup>	25000
Indoor Airflow (CFM)	790
Power Input (KW)	1.94
EER/SEER (BTU/Watt-Hr.) <sup>(b)</sup>	12.00 / 15.00
Sound Power Rating [dB(A)] <sup>(c)</sup>	69.1
<b>PERFORMANCE HEATING</b>	
(High Temp.) BTUH	22400
Power Input (KW)	1.81
(Low Temp.) BTUH	13100
Power Input (KW)	1.65
HSPF (BTUH/Watt-Hr) <sup>(b)</sup>	8.3
<b>POWER CONN. — V/Ph/Hz</b>	208-230/1/60
Min. Brch. Cir. Ampacity <sup>(d)</sup>	18.1
Fuse Size — Max. (amps)	25
Fuse Size — Recmd. (amps)	25
<b>COMPRESSOR</b>	SCROLL
VOLTS/PH/HZ	208-230/1/60
R.L. Amps — L.R. Amps	10.3 / 62
<b>OUTDOOR COIL — TYPE</b>	SPINE FIN
Rows/F.P.I	2 / 24
Face Area (sq. ft.)	13.32
Tube Size (in.)	3/8
Refrigerant Control	EXPANSION VALVE
<b>INDOOR COIL — TYPE</b>	PLATE FIN
Rows/F.P.I	3/15
Face Area (sq. ft.)	3.54
Tube Size (in.)	3/8
Refrigeration Control	EXPANSION VALVE
Drain Conn. Size (in.)	3/4 FEMALE NPT

<b>OUTDOOR FAN — TYPE</b>	PROPELLER
DIA. (IN.)	23.4
DRIVE/NO. SPEEDS	DIRECT / 1
CFM @ 0.0 in. w.g. <sup>(e)</sup>	3270
Motor — HP/R.P.M	1/6 / 830
Volts/Ph/Hz	208-230/1/60
F.L. Amps/L.R Amps	.9 / 1.7
<b>INDOOR FAN — TYPE</b>	CENTRIFUGAL
Dia. x Width (in.)	10 X 10
Drive/No. Speeds	DIRECT / VARIABLE
CFM @ 0.0 in. w.g. <sup>(f)</sup>	SEE FAN PERF TABLE
Motor — HP/R.P.M.	1/2 / VARIABLE
Volts/Ph/Hz	208-230/1/60
F.L. Amps	4.3
<b>FILTER / FURNISHED</b>	NO
Type Recommended	THROWAWAY
Recmd. Face Area (sq. ft) <sup>(g)</sup>	4.0
<b>REFRIGERANT</b>	R-410
Charge (lbs.)	6.25
<b>CHARGING SPECIFICATIONS</b>	
Subcooling	12°
<b>DIMENSIONS</b>	H X D X W
Crated (in.)	46 X 45 X 52
<b>WEIGHT</b>	
Shipping (lbs.) / Net (lbs.)	453 / 357

<sup>(a)</sup> Rated in accordance with AHRI Standard 210/240.

<sup>(b)</sup> Rated in accordance with D.O.E. test procedure.

<sup>(c)</sup> Sound Power values are not adjusted for AHRI 270-95 tonal corrections.

<sup>(d)</sup> Calculated in accordance with currently prevailing Nat'l Electrical Code.

<sup>(e)</sup> Standard Air — Dry Coil — Outdoor.

<sup>(f)</sup> Standard Air — Dry Coil — Indoor

<sup>(g)</sup> Filters must be installed in return air stream. Square footages listed are based on 300 f.p.m. face velocity. If permanent filters are used size per manufacturer's recommendation with a clean resistance of 0.05" W.C.

# Outline Drawing

Figure 1. 2.0 – 3.0 Ton Models

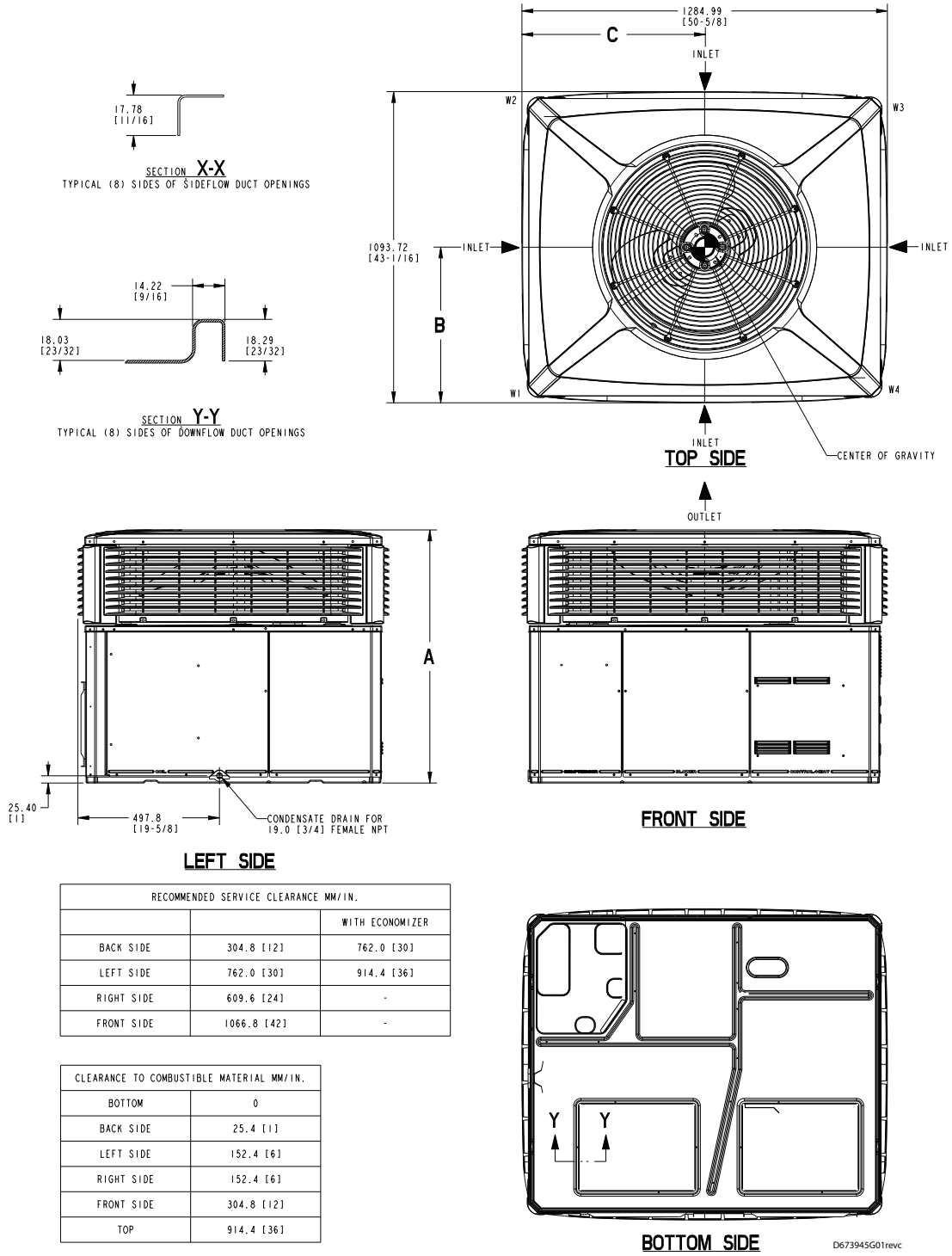
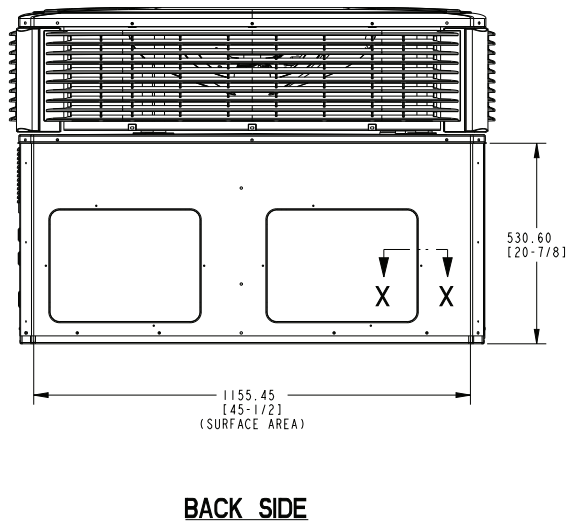
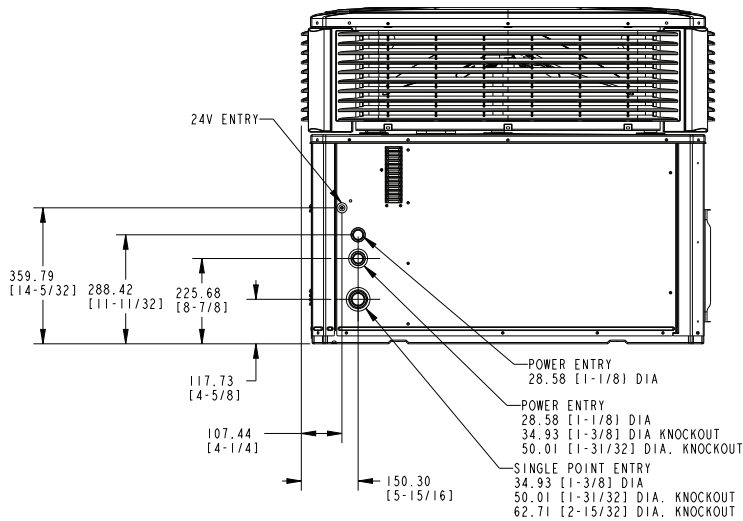
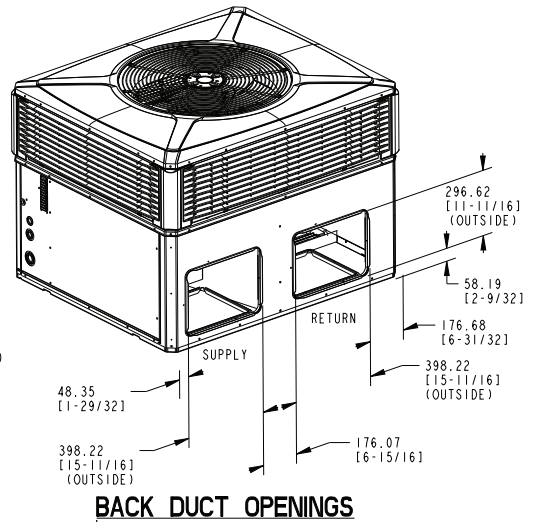
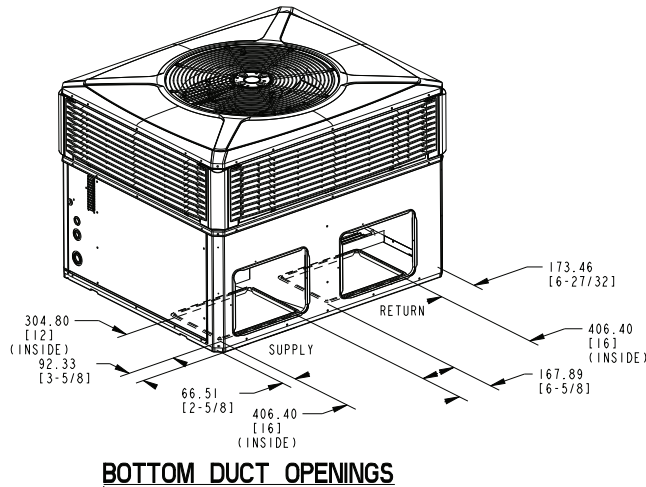

Figure 2. 2.0 – 3.0 Ton Models



MODEL	HEIGHT MM/IN.		APPROX. CORNER WEIGHT - KG/LBS				SHIPPING WEIGHT KG/LBS	TOTAL UNIT WEIGHT KG/LBS	CENTER OF GRAVITY MM/IN.	
	A	W1	W2	W3	W4	B			C	
4TCY4024/030	898.53 [35-3/8]	56.7 [125]	35.8 [79]	25.4 [56]	39.9 [88]	201.6 [444]	157.9 [348]	401.3 [15.8]	508.0 [20.0]	
4TCY5024	898.53 [35-3/8]	51.8 [114]	32.7 [72]	23.2 [51]	36.5 [80]	176.0 [388]	144.2 [318]	401.3 [15.8]	508.0 [20.0]	
4TCY4036	949.33 [37-3/8]	57.6 [127]	36.3 [80]	25.9 [57]	40.8 [90]	204.3 [450]	160.6 [354]	401.3 [15.8]	508.0 [20.0]	
4TCY5030	949.33 [37-3/8]	56.7 [125]	35.8 [79]	25.4 [56]	39.9 [88]	189.6 [418]	157.9 [348]	401.3 [15.8]	508.0 [20.0]	
4TCY5036	949.33 [37-3/8]	57.4 [126]	36.2 [80]	25.7 [57]	40.4 [89]	191.4 [422]	159.7 [352]	401.3 [15.8]	508.0 [20.0]	
4WCY4024/030	898.53 [35-3/8]	57.6 [127]	36.3 [80]	26.3 [58]	41.7 [92]	205.7 [453]	161.9 [357]	401.3 [15.8]	515.6 [20.3]	
4WCY4036	949.33 [37-3/8]	60.8 [134]	38.1 [84]	27.2 [60]	42.6 [94]	212.5 [468]	168.7 [372]	401.3 [15.8]	508.0 [20.0]	
4WCZ6036	949.33 [37-3/8]	60.8 [134]	38.1 [84]	27.2 [60]	42.6 [94]	212.5 [468]	168.7 [372]	401.3 [15.8]	508.0 [20.0]	
4WCY5024	898.53 [35-3/8]	57.6 [127]	36.3 [80]	26.3 [58]	41.7 [92]	205.7 [453]	161.9 [357]	401.3 [15.8]	515.6 [20.3]	
4WCY5030/036	949.33 [37-3/8]	60.8 [134]	38.1 [84]	27.2 [60]	42.6 [94]	212.5 [468]	168.7 [372]	401.3 [15.8]	508.0 [20.0]	

D673645G01revc

# Indoor Fan Performance (230v)

**Table 1. Horizontal Airflow**

4WCY5024A1		EXTERNAL STATIC PRESSURE (IN. WG)										
MOTOR SPEED		0.0	0.1	0.2	0.3	0.4	0.5	0.6	0.7	0.8	0.9	1.0
LOW	WATTS	52	66	89	115	140	164	186	206	229	259	-
	CFM	706	716	727	733	731	719	700	679	662	659	-
MEDIUM	WATTS	72	94	120	148	177	207	233	254	267	290	-
	CFM	786	793	805	813	813	806	793	780	778	799	-
HIGH	WATTS	80	99	125	153	182	211	243	284	342	-	-
	CFM	860	862	877	892	903	904	897	884	869	-	-

**Table 2. Down Airflow**

4WCY5024A1		EXTERNAL STATIC PRESSURE (IN. WG)										
MOTOR SPEED		0.0	0.1	0.2	0.3	0.4	0.5	0.6	0.7	0.8	0.9	1.0
COOLING – LOW	WATTS	35	70	90	108	131	160	188	204	225	250	-
	CFM	695	729	734	728	721	715	705	679	680	685	-
COOLING – MED	WATTS	79	87	105	129	155	180	206	232	264	306	-
	CFM	846	807	802	810	816	813	803	794	800	846	-
COOLING – HIGH	WATTS	86	102	127	156	185	213	242	275	319	-	-
	CFM	884	870	882	899	909	907	895	886	898	-	-

# Supplementary Electric Heater

**Table 3. BAYHTRV – Supplementary Electric Heaters**

UNIT MODEL	ELECTRIC HEATER MODEL	RATED VOLT-AGE	PHASE	AMPS	HEATER CAPACITY		NO. OF STAGES	KW/STAGE		MCA	MAX. FUSE OR HACR CKT BKR SIZE	CANADA ONLY MAX. CKT BKR SIZE
					KW	BTUH		1	2			
4WCY5 024-060	BAYHTRV105	208/240	1	18/21	3.76/5.0	12800/17100	1	3.76/5.0	—	23/26	25/30	25/30
4WCY5 024-060	BAYHTRV108	208/240	1	29/33	6.0/8.0	20500/27300	1	6.0/8.0	—	36/41	40/45	40/45
4WCY5 024-060	BAYHTRV110	208/240	1	36/42	7.5/10.0	25600/34100	1	7.5/10.0	—	45/52	45/60	45/60
4WCY5 030-060	BAYHTRV115	208/240	1	54/63	11.27/15.0	38500/51200	2	7.5/10.0	3.76/5.0	68/78	70/80	70/80
4WCY5 048-060	BAYHTRV120	208/240	1	72/83	15.0/20.0	51200/68300	2	7.5/10.0	7.5/10.0	90/104	90/110	90/110
4WCY5 060	BAYHTRV125	208/240	1	90/104	18.78/25.0	64100/85300	2	11.26/15.0	7.5/10.0	113/130	125/150	125/150

**Table 4. BAYSPEK – Single Power Entry Kit**

SINGLE CIRCUIT POWER AMPACITY AND OVER CURRENT PROTECTION				
UNIT MODEL	SINGLE POWER ENTRY KIT	HEATER MODEL	MIN CKT AMP	MAX OVER-CURRENT DEVICE
4WCY5024A	BAYSPEK60	BAYHTRV105	44	45
		BAYHTRV108	59	60
	BAYSPEK62	BAYHTRV110	70	70

# Full Perimeter Roof Mounting Curb

Figure 3. 2.0 – 3.0 Ton Models

## BAYCURB050A Full Perimeter Roof Mounting Curb

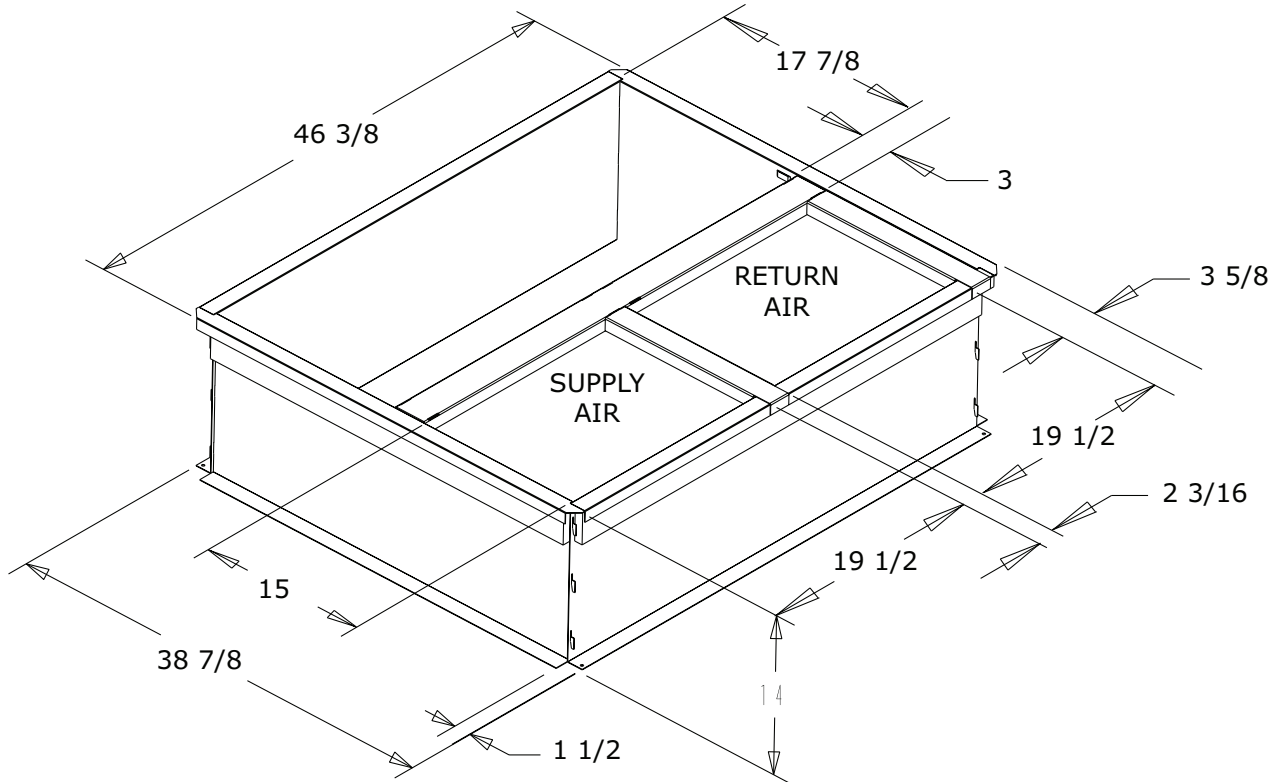

The drawings on this page are prepared by the manufacturer in order to provide detail regarding job layout only. These drawings are not intended to be used as a basis to construct, build or modify the items depicted in the drawings. The manufacturer is not responsible for the unauthorized use of these drawings and expressly disclaims any liability for damages resulting from such unauthorized use.

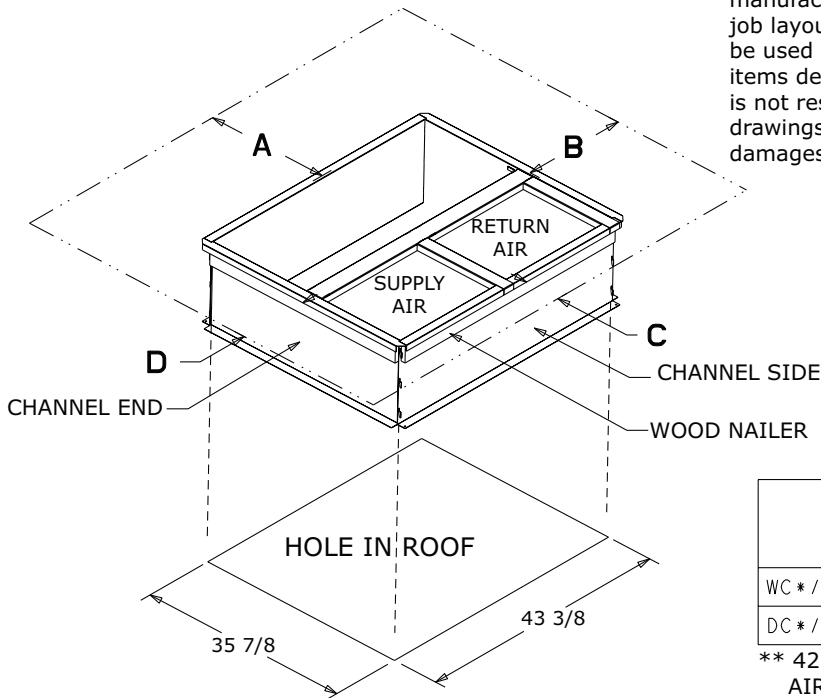

	SERVICE CLEARANCE DIMENSIONS			
	A	B	C	D
WC*/TC*	42.00	36.00	12.00**	24.00
DC*/YC*	42.00	36.00	12.00**	36.00

\*\* 42.00 WITH ECONOMIZER WITH 25% FRESH AIR ACCESSORY



# Optional Equipment – Filter Rack

**Figure 4. BAYFLTR101 Filter Rack (2.0 – 3.0 Ton Models)  
BAYFLTR201 (3.5 – 5.0 Ton Models)  
(Mounts in Filter/Coil Section)**

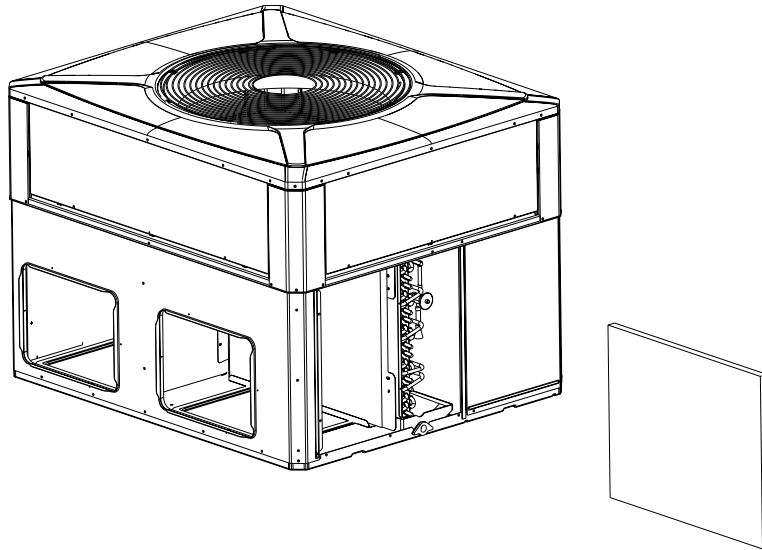

**Figure 5. BAYACCDOR1A Hinged Filter Access Door (2.0 – 3.0 Ton Models)  
BAYACCDOR2A (3.5 – 5.0 Ton Models)  
Replaces Filter/Coil Access Panel**

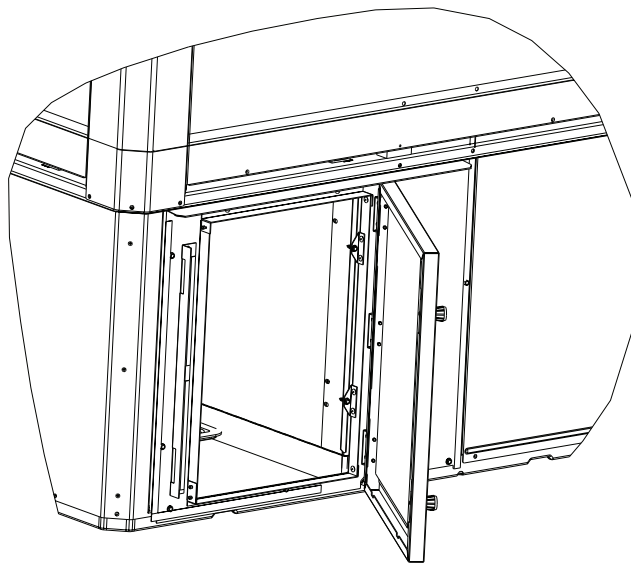

**Note:** The drawings on this page are prepared by the manufacturer in order to provide detail regarding job layout only. These drawings are not intended to be used as a basis to construct, build or modify the items depicted in the drawings. The manufacturer is not responsible for the unauthorized use of these drawings and expressly disclaims any liability for damages resulting from such unauthorized use.

# Optional Equipment – Economizer

**Table 5. BAYECON101,102A Down Discharge Economizer and Rain Hood (Mounts Over Horizontal Return Air Opening)**

	<b>Economizer</b>	<b>Unit Application Models</b>
	BAYECON101A	2.0 – 3.0 Ton Models
	BAYECON102A	3.5 – 5.0 Ton Models

**Table 6. BAYCON200, 201A Horizontal Economizer and Rain Hood**

<b>Economizer</b>	<b>Models</b>	<b>A</b>	<b>B</b>	<b>C</b>	<b>D</b>	<b>E</b>	<b>F</b>
BAYECON200A	2.0 – 3.0 Ton	22"	20"	16-7/8"	15-11/16"	11-11/16"	15"
BAYECON201A	3.5 – 5.0 Ton	26"	22-21/32"	19"	17-11/16"	14-11/16"	21-3/8"

**Note:** The drawings on this page are prepared by the manufacturer in order to provide detail regarding job layout only. These drawings are not intended to be used as a basis to construct, build or modify the items depicted in the drawings. The manufacturer is not responsible for the unauthorized use of these drawings and expressly disclaims any liability for damages resulting from such unauthorized use.

# Optional Equipment – Outside Air Damper

**Table 7. BAYOSAH001 and 002A**

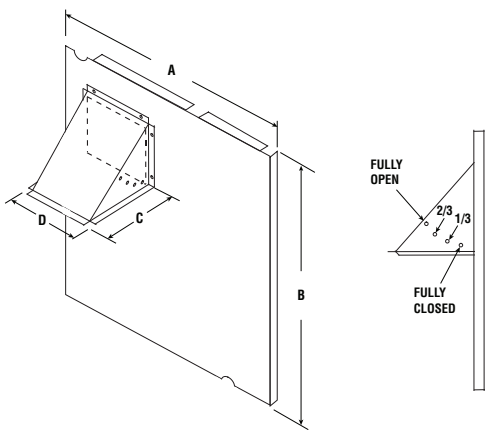

Manual Fresh Air Model	Unit Application Models	A	B	C	D
BAYOSAH001A	2.0 – 3.0 Ton	22-7/16"	20-11/16"	12-3/8"	9-3/16"
BAYOSAH002A	3.5 – 5.0 Ton	25-3/16"	20-11/16"	12-3/8"	9-3/16"

**Table 8. BAYDMPR101 and 102A, 25% Motorized Outside Air Damper (Mounts Over Horizontal Return Air Opening)**

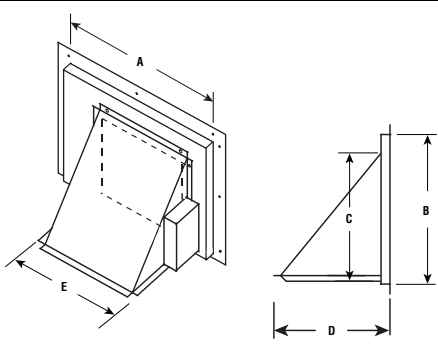

Manual Fresh Air Model	Unit Application Models	A	B	C	D	E
BAYDM-PR101A	2.0 – 3.0 Ton	15-13/16"	11-13/16"	10-1/4"	11-1/2"	12-1/4"
BAYDM-PR102A	3.5 – 5.0 Ton	18-3/16"	15-1/8"	10-1/4"	11-1/2"	12-1/4"

**Note:** The drawings on this page are prepared by the manufacturer in order to provide detail regarding job layout only. These drawings are not intended to be used as a basis to construct, build or modify the items depicted in the drawings. The manufacturer is not responsible for the unauthorized use of these drawings and expressly disclaims any liability for damages resulting from such unauthorized use.

# Mechanical Specifications

## General

The units shall be horizontal airflow as shipped and convertible to downflow. All units shall be factory assembled, piped, internally wired and fully charged with refrigerant. Units shall be certified to UL Standard 1995. All units shall be factory run tested to check cooling operation, fan and blower rotation and control or TXV sequence. Units shall be designed to operate at ambient temperatures between 115°F and 55°F in cooling as manufactured. Cooling performance shall be rated in accordance with AHRI standards.

## Unit Casing

All components shall be mounted in a weather-resistant steel cabinet with an enamel finish. Access panels shall be provided for unit controls and indoor coil and fans. Indoor air section compartment shall be completely insulated with fireproof, permanent, odorless fiber material. Knockouts shall be provided for utility and control connections. Drain connections shall be provided to accommodate indoor water runoff.

## Compressor

The compressor shall be hermetically sealed, high efficiency scroll compressors. Internal overcurrent and over temperature protection, internal pressure relief shall be standard. Other features include centrifugal oil pump, low vibration and noise.

## Refrigeration System

All units shall have refrigerant control. Service pressure tap ports and a refrigerant line filter shall be standard.

**Evaporator Coil** Internally enhanced 3/8" OD seamless copper tubing mechanically bonded to aluminum fins, factory pressure and leak tested at 480 – 650 psig. All units have TXV to control refrigerant flow.

## Condenser Coil

The Spine Fin™ condenser coil shall be continuously wrapped, corrosion resistant all aluminum with minimum brazed joints. This coil is 3/8" OD seamless aluminum tubing glued to a continuous aluminum fin. Coils are lab tested to withstand 2,000 pounds of pressure per square inch. The outdoor coil provides low airflow resistance and efficient heat transfer. The coil is protected on all four sides by louvered panels.

## Indoor Air Fan

Constant Torque, forward-curved, centrifugal wheel in a Composite Vortica® Blower housing. Motor shall have thermal overload protection and permanently lubricated motor bearings. Motor/blower assembly isolated from unit with rubber mounts.

## Outdoor Fan

One direct-drive, statically and dynamically balanced propeller fan shall be used in a draw-through vertical discharge configuration. Permanently lubricated

weather proof motor shall have built-in thermal overload protection.

## System Controls

System controls include condenser fan, evaporator fan and compressor contactors.

## Accessories Roof Curb

The roof curb shall be designed to mate with the unit and provide support and complete weathertight installation when properly installed. Adhesive back polyurethane sealing strips shall be provided to ensure an airtight seal between supply and return openings of the curb and unit. The roof curb design allows field fabricated ductwork to be connected directly to the curb. Curb ships knocked down for field assembly, and includes factory installed wood nailer strips.

## Electric Heaters

Each heater assembly shall include power supply fusing if over 48 amps, automatic resetting limit switches and heat limiters for thermal protection. Heaters shall be provided with polarized plugs for quick connection to unit low voltage wiring. Electric heat modules shall be UL listed.

## Single Source Power Entry

This accessory when used with electric heat accessory shall allow single source power connection to unit and heater combination. Single source power entry kits shall have specific matching heater(s). Kit shall include high voltage terminal blocks, fuse blocks and fuses, cut-to-length interconnecting wiring, and junction box (if required) to provide power sources with fuse protection as required for both the unit and accessory heater. Kit components shall install within the heater cabinet in the heater access section. Single source branch power circuit shall be protected and wired in accordance with local codes.

## Fully Modulating Economizer

This accessory shall be field installed and be composed of the following items: 0–100 % fresh air damper, damper drive motor, fixed dry bulb enthalpy control, and low voltage pigtailed for electrical connections. Solid state enthalpy or differential enthalpy control is optional. Economizer operations shall be controlled by the preset position of the enthalpy control. A barometric relief damper shall be standard with the economizer and provide a pressure operated damper that shall be gravity closing and prohibit entrance of outside air on equipment "off" cycle. Economizer requires BAYRLAY004A relay kit to interface the economizer to the heat pump.

## Manual Outside Air Dampers

Rain hood and screen shall be field installed. Suitable for up to 25% outside air.

### **Control Options**

#### **Standard Indoor Thermostats**

Two stage heating/cooling or one stage heating/cooling thermostats shall be available in either manual or automatic changeover.

#### **Programmable Electronic Night Setting Thermostat**

Programmable electronic thermostat shall provide heating setback and cooling setup with 7-day programming capability. 1H/1C or 2H/2C models available.

## About Trane and American Standard Heating and Air Conditioning

Trane and American Standard create comfortable, energy efficient indoor environments for residential applications. For more information, please visit [www.trane.com](http://www.trane.com) or [www.americanstandardair.com](http://www.americanstandardair.com).



The AHRI Certified mark indicates company participation in the AHRI Certification program. For verification of individual certified products, go to [ahridirectory.org](http://ahridirectory.org).

The manufacturer has a policy of continuous data improvement and it reserves the right to change design and specifications without notice. We are committed to using environmentally conscious print practices.