

TAG: _____

SUBMITTAL

**3 Ton Convertible Heat Pump Packaged Units
4WCZ6036B3000A**

PRODUCT SPECIFICATIONS

MODEL	4WCZ6036B3000A
RATED Volts/Ph/Hz	208-230/3/60
Performance Cooling	
BTUH (High)	36000
Indoor Airflow (CFM)	1125
Power Input (KW)	2.89
BTUH (Low)	28800
Indoor Airflow (CFM)	825
Power Input (KW)	1.65
EER - HI / LOW / SEER	12.2 / 17.45 / 16
Sound Power Rating [dB(A)] ^②	70
Performance Heating^①	
(High Temp.)BTUH / COP (High)	31000 / 3.43
Power Input (KW)	2.65
(Low Temp.) BTUH / COP (High)	19200 / 2.30
Power Input (KW)	2.45
(High Temp.)BTUH / COP (Low)	22400 / 3.43
Power Input (KW)	1.92
(Low Temp.) BTUH / COP (Low)	12000 / 1.89
Power Input (KW)	1.86
HSPF (BTU / Watt-Hr.) ^⑥	8.3
POWER CONN. — V/Ph/Hz	
Min. Brch. Cir. Ampacity ^③	19.7
Fuse Size — Max. / Recmd. (amps)	30 / 30
COMPRESSOR	
Volts/Ph/Hz	2-STAGE SCROLL 208-230/3/60
R.L. Amps — L.R. Amps	11.6 / 73
OUTDOOR COIL — TYPE	
Rows/F.P.I.	SPINE-FIN 2 / 24
Face Area (sq.ft.)	15.49
Tube Size (in.)	3/8
Refrigerant Control	EXPANSION VALVE
INDOOR COIL — TYPE	
Rows/F.P.I.	PLATE FIN 4 / 15
Face Area (sq.ft.)	3.54
Tube Size (in.)	3/8
Refrigerant Control	EXPANSION VALVE
Drain Conn. Size (in.)	3/4 FEMALE NPT
OUTDOOR FAN — TYPE	
Dia. (in.)	PROPELLER 23.4
Drive/No. Speeds	DIRECT / 1
CFM @ 0.0 in. w.g. ^④	3020
Motor — HP/R.P.M.	1/6 / 830
Volts/Ph/Hz	208-230/1/60
F.L. Amps/L.R. Amps	0.9 / 1.65
INDOOR FAN — TYPE	
Dia x Width (in.)	CENTRIFUGAL 10 X 10
Drive/No. Speeds	DIRECT / VARIABLE
CFM @ 0.0 in. w.g. ^⑤	SEE FAN PERFORMANCE TABLE
Motor — HP/R.P.M.	1/2 / VARIABLE
Volts/Ph/Hz	208-230/1/60
F.L. Amps/L.R. Amps	4.3 / 4.3
FILTER / FURNISHED	
Type Recommended	NO THROWAWAY
Recmd. Face Area (sq. ft.) ^⑦	4.0
REFRIGERANT / Charge (lbs.)	
	R410A / 7.8
DIMENSIONS	
Crated (in.)	H X W X L 47.86 / 44.5 / 52.03
WEIGHT / Shipping / Net (lbs.)	
	468 / 372

- ① Certified in accordance with the Unitary Air-Conditioner Equipment certification program, which is based on AHRI Standard 210/240.
- ② Sound Power values are not adjusted for AHRI 270-95 tonal corrections.
- ③ Calculated in accordance with currently prevailing Nat'l Electrical Code.
- ④ Standard Air — Dry Coil — Outdoor.
- ⑤ Standard Air — Wet Coil — Indoor.
- ⑥ Rated in accordance with D.O.E. test procedure.
- ⑦ Filters must be installed in return air system. Square footages listed are based on 300 f.p.m. face velocity. If permanent filters are used size per manufacturer's recommendations with clean resistance of 0.05" W.C.

Dimensional Data and Weights

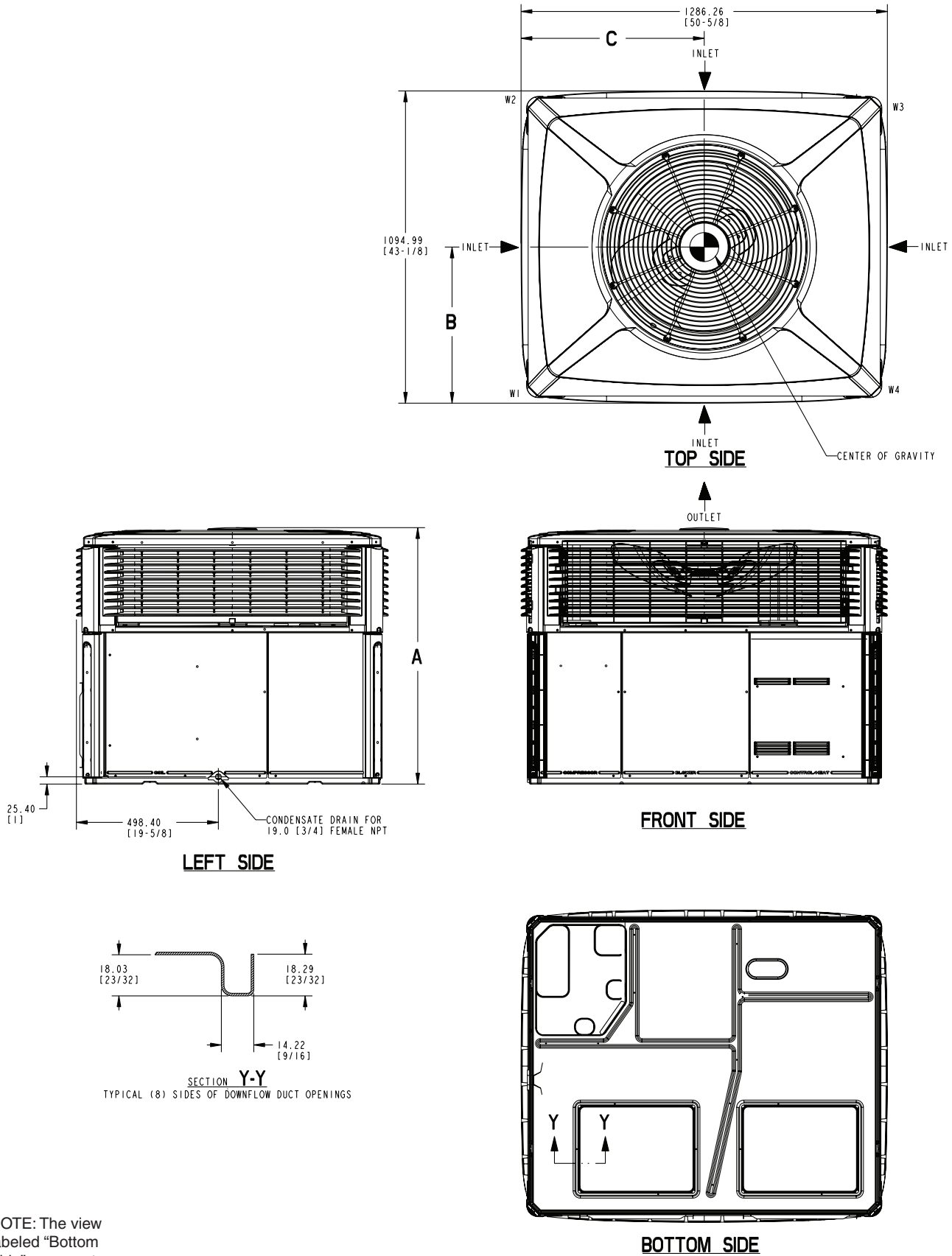

NOTE: The view labeled "Bottom Side" represents the Base as viewed looking up from underneath the unit.

Figure 1. WCZ6036 (1 of 3)

Dimensional Data and Weights

RECOMMENDED SERVICE CLEARANCE MM/IN.		
		WITH ECONOMIZER
BACK SIDE	304.8 [12]	762.0 [30]
LEFT SIDE	762.0 [30]	914.4 [36]
RIGHT SIDE	609.6 [24]	-
FRONT SIDE	1066.8 [42]	-

CLEARANCE TO COMBUSTIBLE MATERIAL MM/IN.	
BOTTOM	0
BACK SIDE	25.4 [1]
LEFT SIDE	152.4 [6]
RIGHT SIDE	152.4 [6]
FRONT SIDE	304.8 [12]
TOP	914.4 [36]

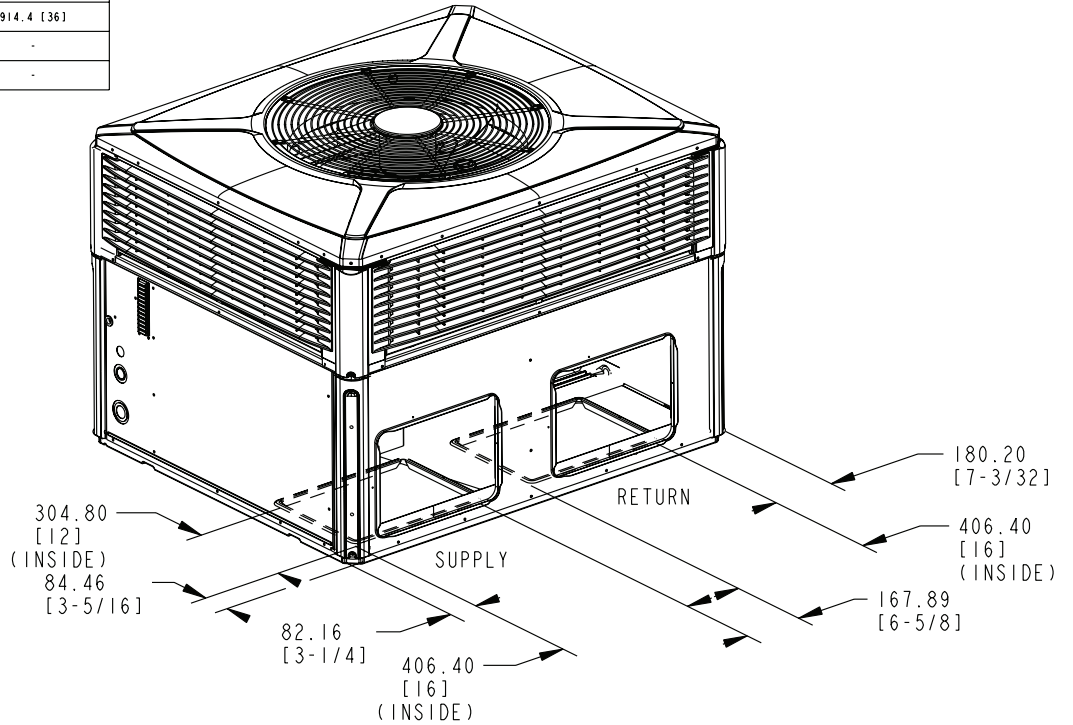

BOTTOM DUCT OPENINGS

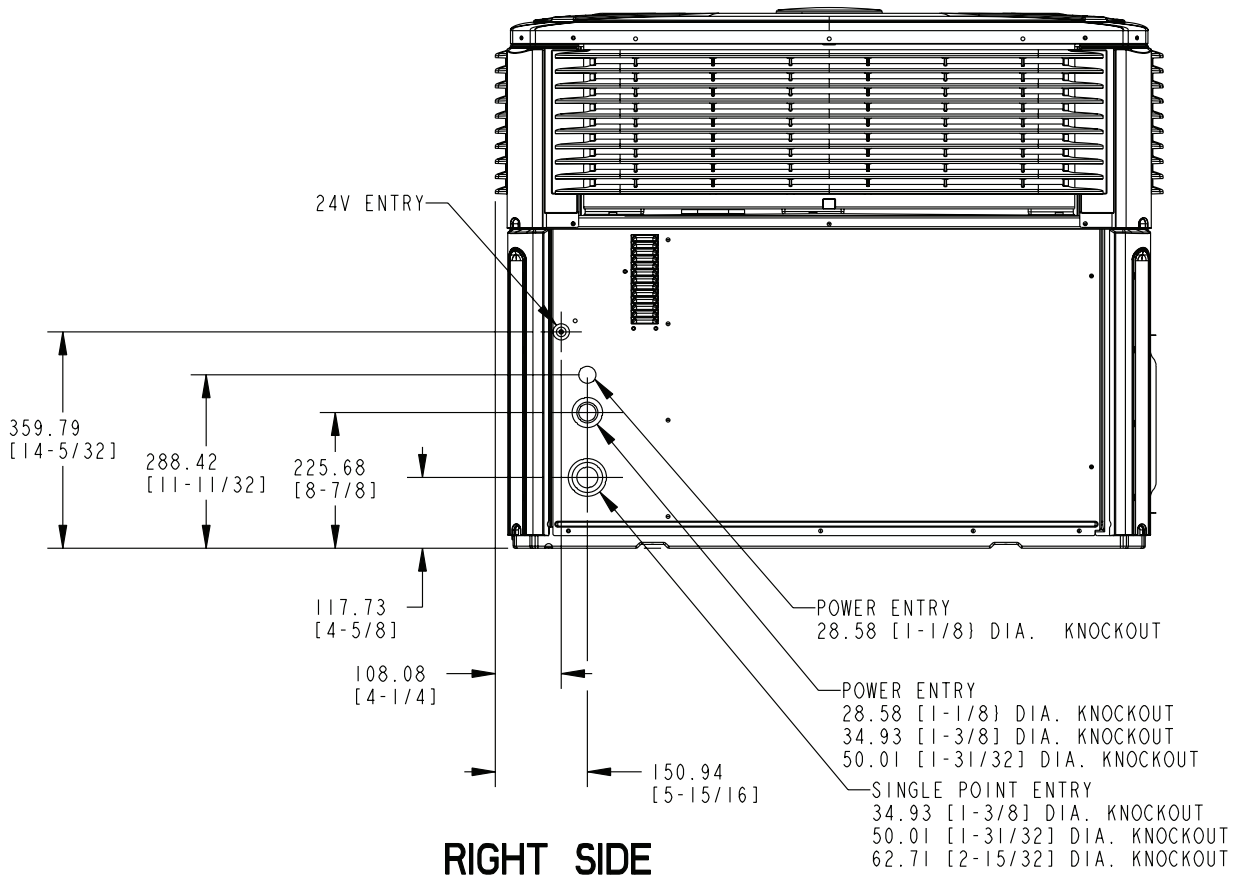

RIGHT SIDE

Figure 2. WCZ6036 (2 of 3)

Dimensional Data and Weights

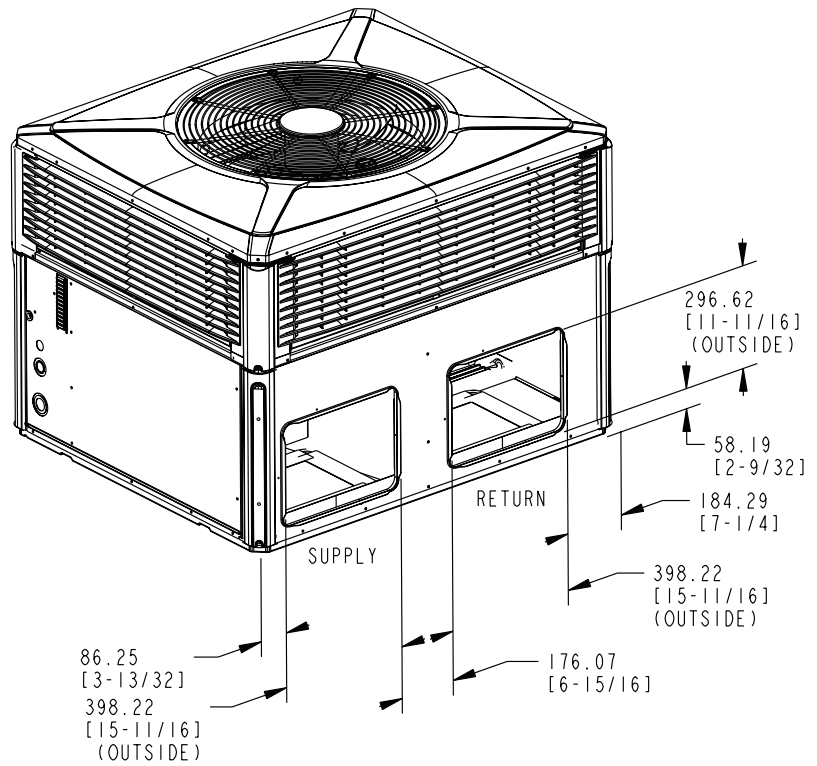

BACK DUCT OPENINGS

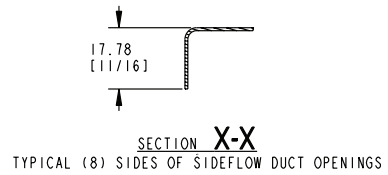
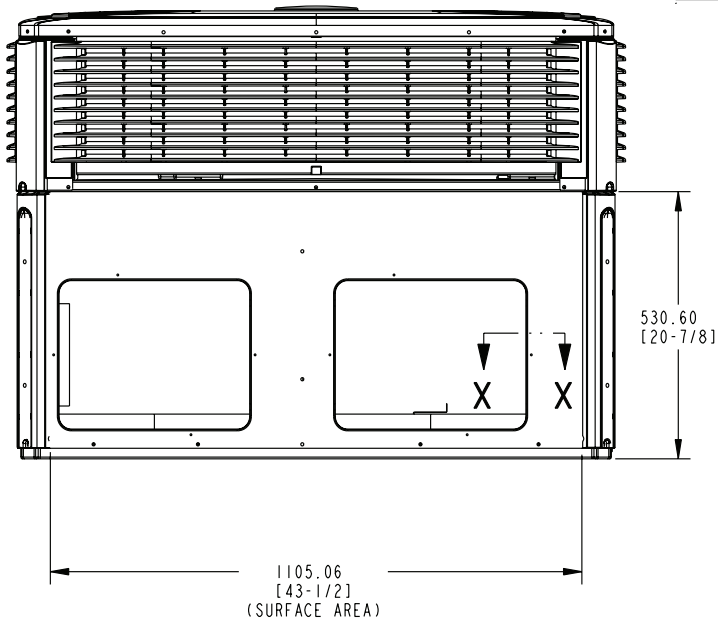

BACK SIDE

MODEL	HEIGHT MM/IN.	APPROX. CORNER WEIGHT - KG/LBS				SHIPPING WEIGHT KG/LBS	TOTAL UNIT WEIGHT KG/LBS	CENTER OF GRAVITY MM/IN.	
	A	W1	W2	W3	W4			B	C
4TCY4024/030	898.53 [35-3/8]	56.7 [125]	35.8 [79]	25.4 [56]	39.9 [88]	201.6 [444]	157.9 [348]	401.3 [15.8]	508.0 [20.0]
4TCY4036	949.33 [37-3/8]	57.6 [127]	36.3 [80]	25.9 [57]	40.8 [90]	204.3 [450]	160.6 [354]	401.3 [15.8]	508.0 [20.0]
4WCY4024/030	898.53 [35-3/8]	57.6 [127]	36.3 [80]	26.3 [58]	41.7 [92]	205.7 [453]	161.9 [357]	401.3 [15.8]	515.6 [20.3]
4WCY4036	949.33 [37-3/8]	60.8 [134]	38.1 [84]	27.2 [60]	42.6 [94]	212.5 [468]	168.7 [372]	401.3 [15.8]	508.0 [20.0]
4WCZ6036	949.33 [37-3/8]	60.8 [134]	38.1 [84]	27.2 [60]	42.6 [94]	212.5 [468]	168.7 [372]	401.3 [15.8]	508.0 [20.0]

Figure 3. WCZ6036 (3 of 3)

Indoor Blower Performance

Indoor Fan Performance 4WCZ6036

Horizontal		External Static Pressure (in. wg)										
		0	0.1	0.2	0.3	0.4	0.5	0.6	0.7	0.8	0.9	1
350 CFM/Ton Setting	Low	-	741	743	744	744	743	742	740	737	-	-
	High	-	1059	1062	1063	1063	1062	1059	1057	1053	-	-
400 CFM/Ton Setting	Low	-	825	837	843	844	844	842	839	836	-	-
	High	-	1179	1196	1204	1206	1205	1203	1199	1194	-	-
450 CFM/Ton Setting	Low	-	975	964	959	957	953	949	945	945	-	-
	High	-	1394	1377	1371	1367	1362	1355	1350	1350	-	-

Down Flow		External Static Pressure (in. wg)										
		0	0.1	0.2	0.3	0.4	0.5	0.6	0.7	0.8	0.9	1
350 CFM/Ton Setting	Low	-	722	745	747	744	742	743	744	736	-	-
	High	-	1032	1064	1066	1063	1060	1062	1063	1052	-	-
400 CFM/Ton Setting	Low	-	830	841	842	840	839	836	836	828	-	-
	High	-	1185	1201	1203	1201	1196	1197	1194	1184	-	-
450 CFM/Ton Setting	Low	-	976	965	964	963	956	946	941	949	-	-
	High	-	1397	1376	1377	1376	1366	1354	1344	1356	-	-

4WCZ6036 AIRFLOW WITH AUXILIARY HEAT (CFM)

SWITCH SETTINGS		SELECTION	NOMINAL AIRFLOW
7-OFF	8-OFF	LOW	1050 CFM
7-ON	8-OFF	HIGH	1200 CFM
7-OFF	8-ON	HIGH	1200 CFM
7-ON	8-ON	HIGH	1200 CFM

COOLING FAN DELAY OPTIONS

SWITCH SETTINGS		DELAY	NOMINAL AIRFLOW
5-OFF	6-OFF	NONE	100%
5-ON	6-OFF	45 SEC	100%
5-OFF	6-ON	90 SEC	50%
5-ON	6-ON	**	50-100%

** This ENHANCED MODE selection provides a ramping up and ramping down of the indoor blower speed to provide improved comfort, quietness, and potential energy savings. The Graph below shows the ramping process

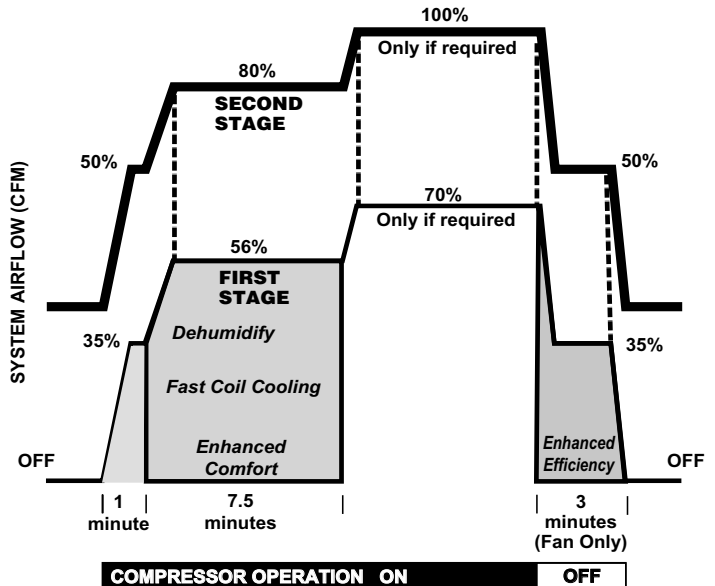

Supplementary Electric Heaters

BAYHTRV305, 308, 310, 315E

UNIT MODEL	ELECTRIC HEATER MODEL	RATED VOLTAGE	PHASE	AMPS	HEATER CAPACITY		NO. OF STAGES	KW/STAGE		MCA	MAX FUSE OR HACR CKT BKR SIZE (4)	CANADA ONLY MAX. CKT BKR SIZE (5)
					KW	BTUH		1	2			
^WCZ6036-060†3	BAYHTRV305E	208/240	3	10/12	3.76/5.0	12800/17100	1	3.76/5.0		13/15	15/15	15/15
^WCZ6036-060†3	BAYHTRV308E	208/240	3	17/19	6.0/8.0	20500/27300	1	6.0/8.0		21/24	25/25	25/25
^WCZ6036-060†3	BAYHTRV310E	208/240	3	21/24	7.5/10.0	25600/34100	1	7.5/10.0		26/30	30/30	30/30
^WCZ6036-060†3	BAYHTRV315E	208/240	3	31/36	11.27/15.0	38500/51200	2	7.5/10.0	3.76/5.0	39/45	40/45	40/45

Single Power Entry Kit

BAYSPEK61, 63E

SINGLE POWER ENTRY KIT	HEATER MODEL	UNIT MODEL	MIN CKT. AMP.	MAX OVER CURRENT PROTECT DEVICE
BAYSPEK061E	BAYHTRV305E	4WCZ6036	34	40
BAYSPEK063E	BAYHTRV308E	4WCZ6036	43	45
	BAYHTRV310E	4WCZ6036	49	50

Optional Equipment

BAYCURB050A FULL PERIMETER ROOF MOUNTING CURB FOR 4WCZ6036

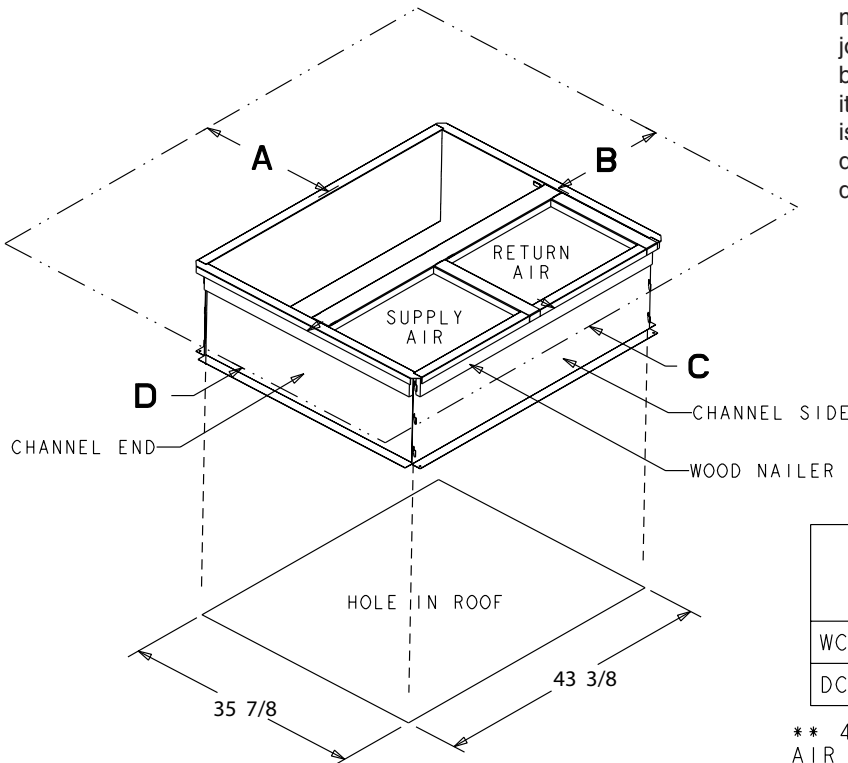
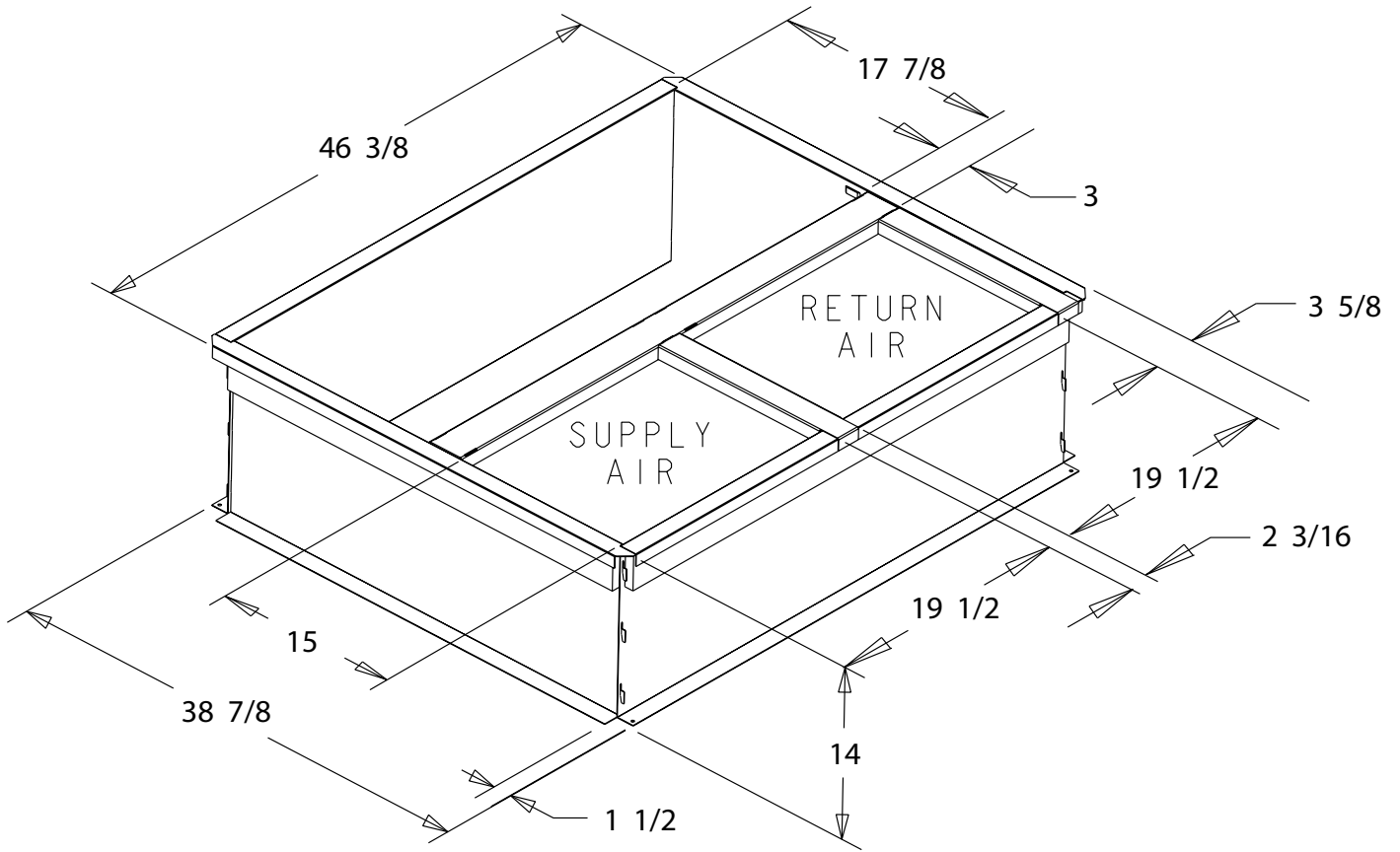

The drawings on this page are prepared by the manufacturer in order to provide detail regarding job layout only. These drawings are not intended to be used as a basis to construct, build or modify the items depicted in the drawings. The manufacturer is not responsible for the unauthorized use of these drawings and expressly disclaims any liability for damages resulting from such unauthorized use.

	SERVICE CLEARANCE DIMENSIONS			
	A	B	C	D
WC*/TC*	42.00	36.00	12.00**	24.00
DC*/YC*	42.00	36.00	12.00**	36.00

** 42.00 WITH ECONOMIZER WITH 25% FRESH AIR ACCESSORY

Optional Equipment

BAYFLTR101, 201B, 1" - 2" Filter Rack (Mounts in Filter/Coil Section)

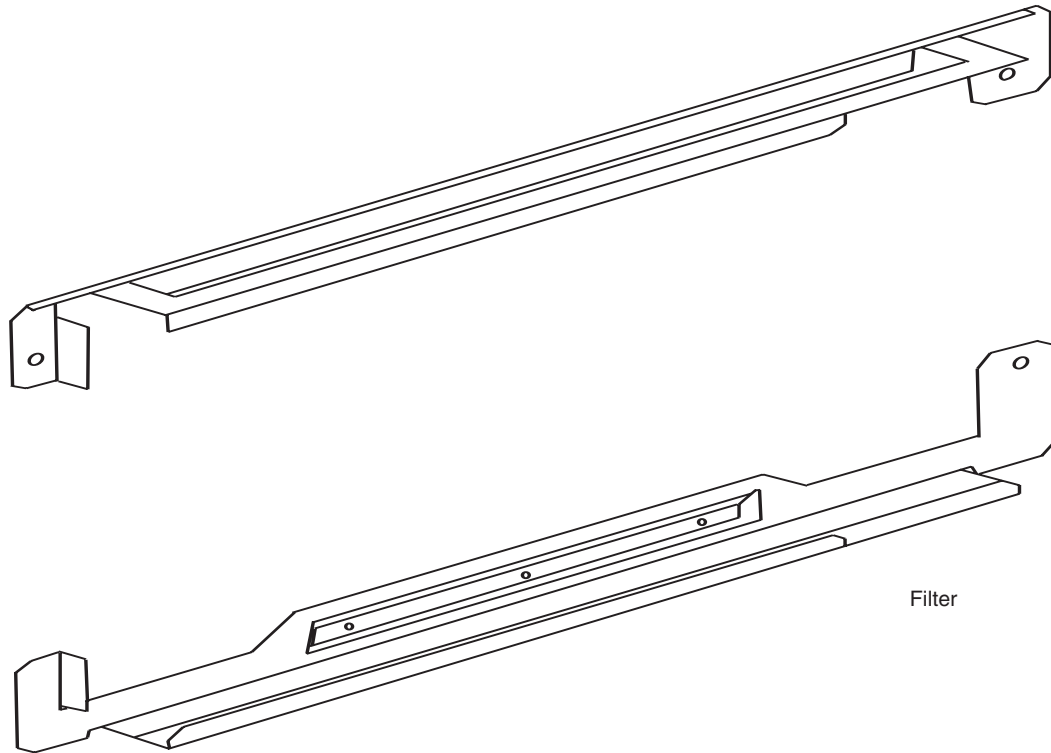

BAYACCDOR1A & BAYACCDOR2A Hinged Filter Access Door Replaces Filter/Coil Access Panel

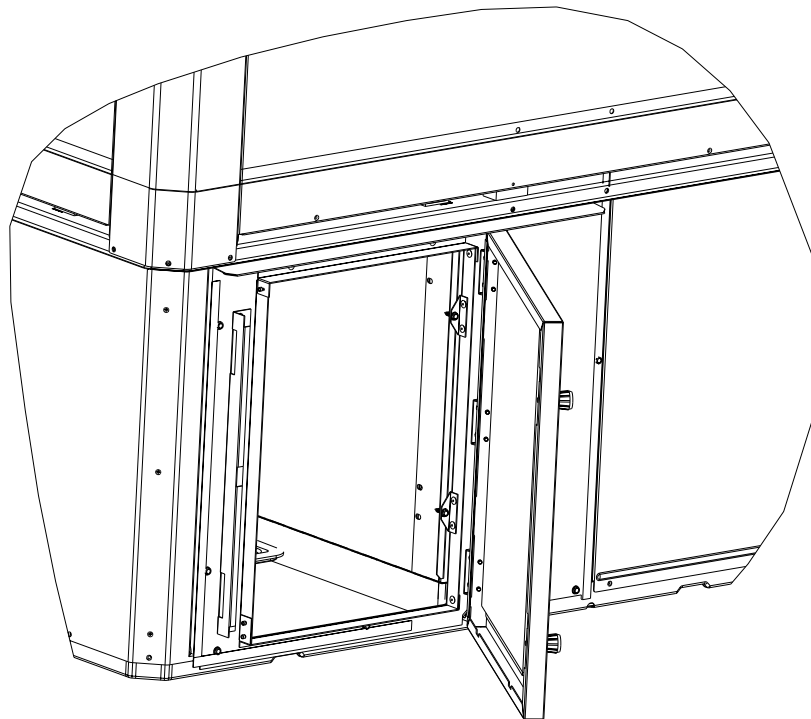

The drawings on this page are prepared by the manufacturer in order to provide detail regarding job layout only. These drawings are not intended to be used as a basis to construct, build or modify the items depicted in the drawings. The manufacturer is not responsible for the unauthorized use of these drawings and expressly disclaims any liability for damages resulting from such unauthorized use.

Optional Equipment

BAYECON103,104A Down Discharge Economizer and Rain Hood (Mounts Over Horizontal Return Air Opening)

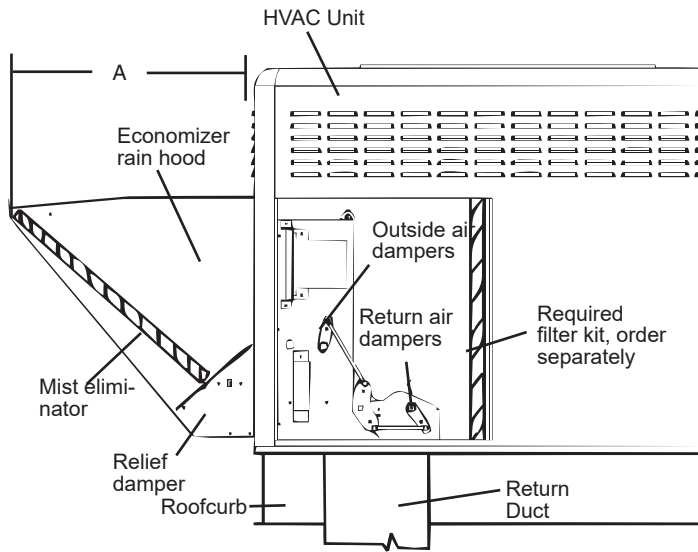

Economizer	Models	A
BAYECON103A	4WCZ6036 4DCZ6036 4YCZ6036	20 1/8"
BAYECON104A	4WCZ6048-060 4DCZ6048-060 4YCZ6048-060	24 3/8"

BAYCON203,204A Horizontal Economizer and Rain Hood

The drawings on this page are prepared by the manufacturer in order to provide detail regarding job layout only. These drawings are not intended to be used as a basis to construct, build or modify the items depicted in the drawings. The manufacturer is not responsible for the unauthorized use of these drawings and expressly disclaims any liability for damages resulting from such unauthorized use.

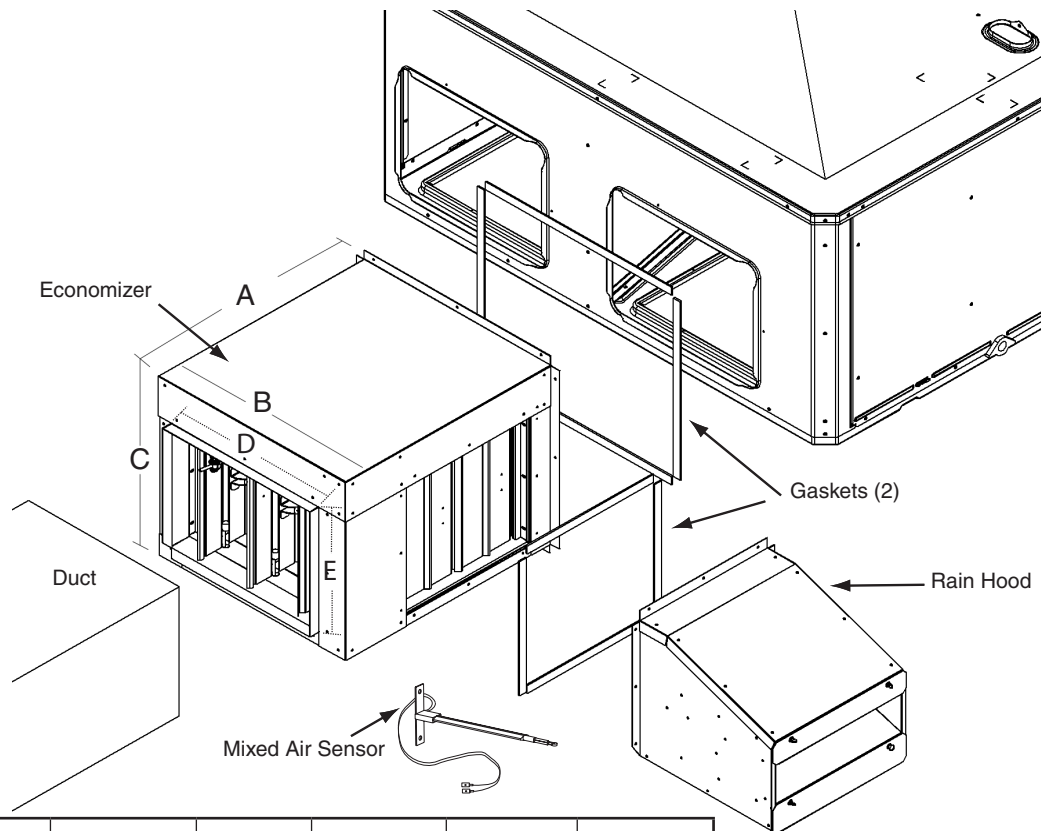

Economizer	A	B	C	D	E	F
BAYECON203AA	22"	20"	16 7/8"	15 11/16"	11 11/16"	15"
BAYECON204AA	26"	22 21/32"	19"	17 11/16"	14 11/16"	21-3/8"

Optional Equipment

BAYOSAH001,002A, 25% Outside Air Damper (Replaces Filter/Coil Access Panel)

The drawings on this page are prepared by the manufacturer in order to provide detail regarding job layout only. These drawings are not intended to be used as a basis to construct, build or modify the items depicted in the drawings. The manufacturer is not responsible for the unauthorized use of these drawings and expressly disclaims any liability for damages resulting from such unauthorized use.

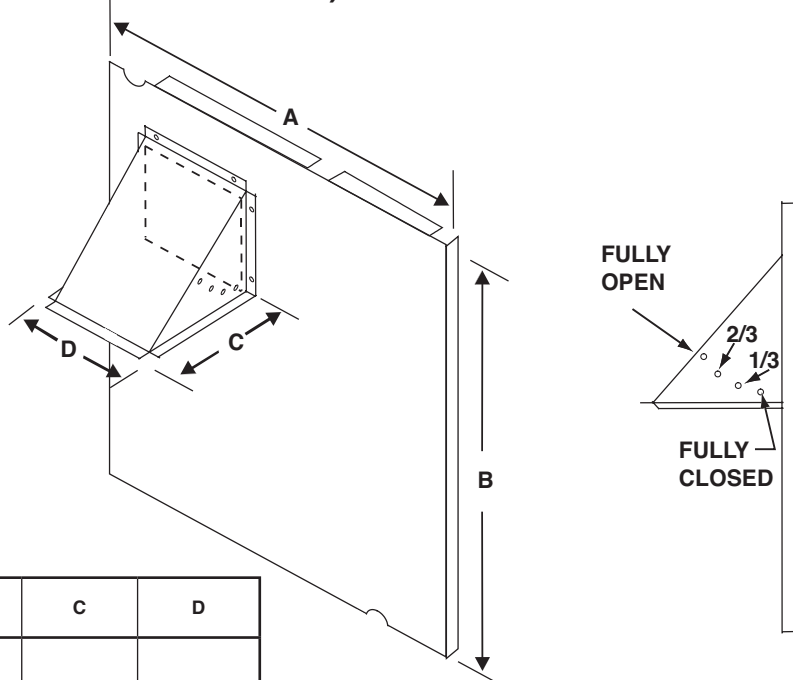

Manual Fresh Air Model	Unit Application Models	A	B	C	D
BAYOSAH001	4YC,WC3018-036	22 7/16"	20 11/16"	12 3/8"	9 3/16"
	4TC*3018-036				
	4W/T/Y/DCY4024-036				
	4W/Y/DCZ6036				
BAYOSAH002	4YC,WC3042-060	25 3/16"	20 11/16"	12 3/8"	9 3/16"
	4TC*3042-060				
	4W/T/Y/DCY4042-060				
	4W/Y/DCZ6048-060				

BAYDMPR101,102A, 25% Motorized Outside Air Damper (Mounts Over Horizontal Return Air Opening)

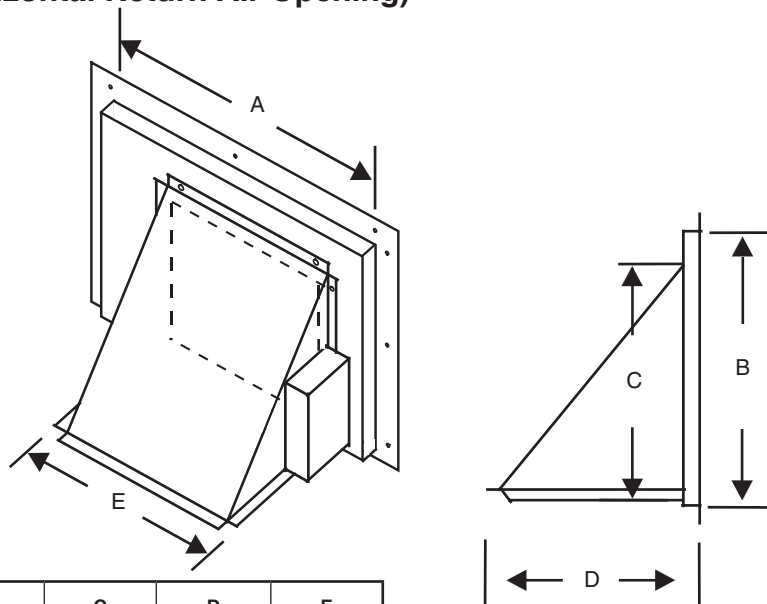

	Unit Application Models	A	B	C	D	E
BAYDMPR101A	4YC,WC3018-036	15 13/16"	11 13/16"	10 1/4"	11 1/2"	12 1/4"
	4TC3018-036					
	4W/T/Y/DCY4024-036					
	4W/Y/DCZ6036					
BAYDMPR102A	4YC,WC3042-060	18 3/16"	15 1/8"	10 1/4"	11 1/2"	12 1/4"
	4TC3042-060					
	4W/T/Y/DCY4042-060					
	4W/Y/DCZ6048-060					

Mechanical Specifications

General

The units shall be horizontal airflow as shipped and convertible to downflow. All units shall be factory assembled, piped, internally wired and fully charged with refrigerant. Units shall be certified to UL Standard 1995. All units shall be factory run tested to check cooling operation, fan and blower rotation and control or TXV sequence. Units shall be designed to operate at ambient temperatures between 115°F and 55°F in cooling as manufactured. Cooling performance shall be rated in accordance with A.H.R.I. standards.

Unit Casing

All components shall be mounted in a weather-resistant steel cabinet with an enamel finish. Access panels shall be provided for unit controls and indoor coil and fans. Indoor air section compartment shall be completely insulated with fireproof, permanent, odorless glass fiber material. Knockouts shall be provided for utility and control connections. Drain connections shall be provided to accommodate indoor water runoff.

Compressor

The compressor shall be hermetically sealed, high efficiency Climatuff® two-stage compressors. Internal overcurrent and over temperature protection, internal pressure relief shall be standard.

Refrigeration System

All units shall have TXV in cooling and TXV in heating. Service pressure tap ports, and a refrigerant line filter dryer shall be standard.

Indoor Coil

Coils shall be internally finned or smooth bore 3/8" copper tubes mechanically bonded to configured aluminum plate fin as standard. Evaporator coil leak and pressure tested to 200 psig; condenser coil tested to 450 psig.

Condenser Coil —

The Spine Fin™ condenser coil shall be continuously wrapped, corrosion resistant all aluminum with minimum brazed joints. This coil is 3/8 inch O.D. seamless aluminum tubing glued to a continuous aluminum fin. Coils are lab tested to withstand 2,000 pounds of pressure per square inch. The outdoor coil provides low airflow resistance and efficient heat transfer. The coil is protected on all four sides by louvered panels.

Indoor Air Fan — Direct-drive, forward-curved, centrifugal wheel in a Composite Vortica® Blower housing. Motor shall have thermal overload protection. Permanently lubricated motor bearings. Motor/blower assembly isolated from unit with rubber mounts.

Condenser Fan — Direct-drive, draw thru propeller type. Weather-proofed permanent split capacitor fan motor shall have built-in thermal overload and permanently lubricated motor bearings.

System Controls

System controls include condenser fan, evaporator fan and compressor contactors.

Accessories

Roof Curb — The roof curb shall be designed to mate with the unit and provide support and complete weathertight installation when properly installed. Adhesive back polyurethane sealing strips shall be provided to ensure an airtight seal between supply and return openings of the curb and unit. The roof curb design allows field fabricated ductwork to be connected directly to the curb. Curb ships knocked down for field assembly, and includes factory-installed wood nailer strips.

Electric Heaters — Each heater assembly shall include power supply fusing if over 48 amps, automatic resetting limit switches and heat limiters for thermal protection. Heaters shall be provided with polarized plugs for quick connection to unit low voltage wiring. Electric heat modules shall be UL listed.

Single Source Power Entry — This accessory when used with electric heat accessory shall allow single source power connection to unit and heater combination. Single source power entry kits shall have specific matching heater(s). Kit shall include high voltage terminal blocks, fuse blocks and fuses, cut-to-length interconnecting wiring, and junction box (if required) to provide power sources with fuse protection as required for both the unit and accessory heater. Kit components shall install within the unit cabinet in the heater access section. Single source branch power circuit shall be protected and wired in accordance with local codes.

Fully Modulating Economizer — This accessory shall be field installed and be composed of the following items: 0-100% fresh air damper, damper drive motor, fixed dry bulb enthalpy control, and low voltage wiring plug for electrical connections. Solid state enthalpy or differential enthalpy control is optional. Economizer operations shall be controlled by the preset position of the enthalpy control. A barometric relief damper shall be standard with the economizer and provide a pressure operated damper that shall be gravity closing and prohibit entrance of outside air on equipment "off" cycle. Economizer requires BAYRLAY004A relay kit to interface the economizer to the heat pump.

Manual Outside Air Dampers — Rain hood and screen shall be field installed. Suitable for up to 25% outside air.

Start Kit — Extra compressor starting capacity for single phase equipment.

Control Options

Standard Indoor Thermostats — Two stage heating/cooling or one stage heating/cooling thermostats shall be available in either manual or automatic changeover.

Programmable Electronic Night Setback Thermostat — Programmable electronic thermostat shall provide heating setback and cooling setup with 7-day, programming capability. 1H/1C or 2H/2C models available.

About Trane and American Standard Heating and Air Conditioning

Trane and American Standard create comfortable, energy efficient indoor environments for residential applications. For more information, please visit www.trane.com or www.americanstandardair.com

The manufacturer has a policy of continuous data improvement and it reserves the right to change design and specifications without notice. We are committed to using environmentally conscious print practices.



The AHRI Certified mark indicates company participation in the AHRI Certification program. For verification of individual certified products, go to ahridirectory.org.